



ITEC NET

SPIDERLINE 16/03

MANUAL



Designed and Manufactured by
ITEC Tontechnik und
Industrieelektronik GesmbH
8200 Laßnitzthal 300
Austria / Europe

 **ITEC**
itec-audio.com

Dear Customer,

The main focus of our research work is and always has been the development of practical devices that are flexible, versatile, reliable, future-proof but still easy to handle. In close cooperation with electrical consultants, system architects and operators of public address systems the ITECNET SpiderLine16 has emerged and grown. In addition, all our know-how from many years of experience in the field of audio and digital technology has been integrated into this product.

Unlike any other known device, it offers the possibility of building the largest and most complex audio systems, with relatively simple and well arranged operation and configuration.

This manual describes the hardware of the SpiderLine16, shows the construction and the wiring of the various audio and logic I/Os and thus serves the audio system designer / integrator in the conceptual design phase respectively during the set-up process of audio networks. Numerous examples illustrate the optimum usage and the professional installation of controls and other devices.

For knowing the entire system, all its possibilities and for executing the necessary configuration tasks the software manual is required in addition. Please observe during the installation / operation of the ITEC SpiderLine16 all listed safety instructions in this manual; furthermore data and examples provided ensuring the optimum usage of the device.

Lots of joy and success - The ITEC Acoustics Team

Safety instructions

When installing the device, the local connecting conditions, the required protective measures and all relevant standards have to be observed.

The installation and configuration of the ITEC SpiderLine16 must be performed by trained personnel only. For the configuration the original software ITEC NetDesign has to be used exclusively.

The power connection is carried out via the original power supply unit or directly to any existing 24 V DC power supply (emergency current).

Please note that the ground connector of the device (audio ground and ground of all digital audio interfaces) is electrically not connected to the negative pole of the DC supply.

Please observe during the installation, that no multiple connections between the ground connector of the device and the 24 V negative pole are put in place (see also chapter „mass concept“).

When installed in switch cabinets, pre-cautions need to be taken to ensure sufficient air exchange to avoid overheating of the device.

Due to the great depth of the housing, support rails are absolutely necessary for installation in 19“ cabinets.



The picture shows the installation in a 19“ cabinet with support rails, Rittal system.

When connecting to other devices (e.g.: sound sources, computers), the exact pin configuration and the specifications of inputs and outputs need to be observed.

Only a connection to networks, which are compliant to IEEE 802.3 (Ethernet), is possible.

Never try to open the device by force or by unscrewing. The product does not contain parts that can be repaired by amateurs. Please contact the manufacturer or a local distributor.

Do not apply temperatures above 50 °C, humidity larger than 95% or rain to the device.

Caution: Before carrying out any modifications on the device (only by qualified personnel) the power supply has to be disconnected.

The device is designed for installations in 19“ cabinets / rack / frame / housing. Improper installations in furniture, cabinets or distribution systems, as well as free installation have to be avoided.

The audio network ITECNET

ITECNET is a decentralized, Ethernet-based audio network for the simultaneous transmission of up to 64 audio channels with the highest audio quality. At the same time, a huge number of system data, measurement data and IOs are controlled and transmitted. With four audio inputs, four audio outputs, serial ports and I/Os the SpiderLine16 is one of the most important system components.

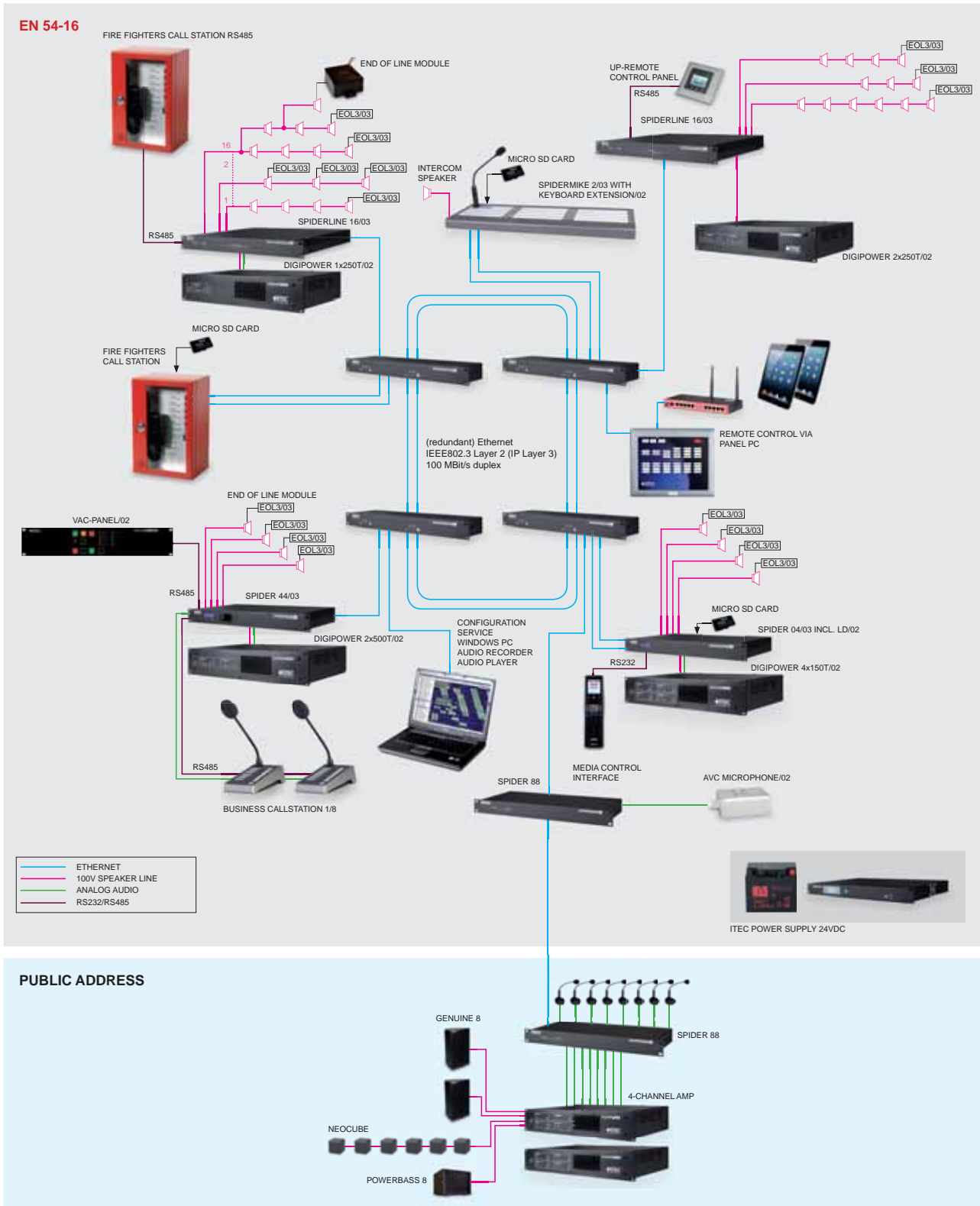

Operating and display elements on the front-panel

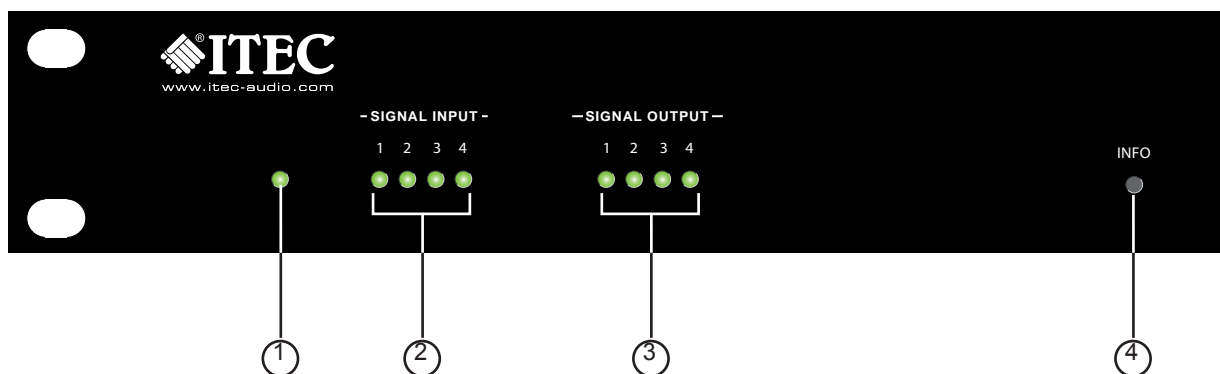

- 1 Indicator LED: green: normal operation, yellow = failure
- 2 Signal level indication for the 4 line/mic inputs
- 3 Signal level indication for the 4 line/mic outputs
- 4 Info button to switch display mode of the status indicators (see Figure 5)

Connectors on the rear panel

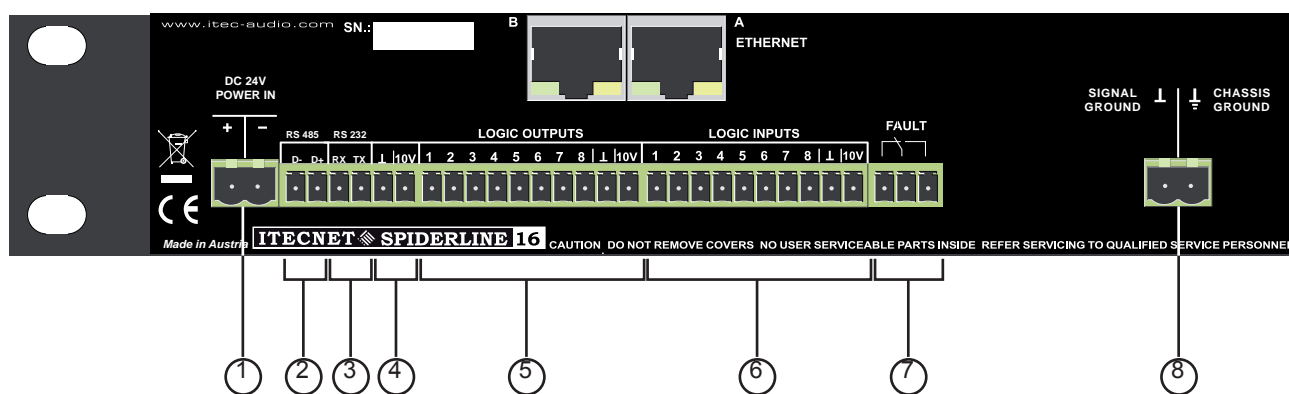

- 1 24VDC power supply, power consumption depends on the load of the internal amplifier. Up to 5A. max. Cable section 4 mm²
- 2 RS 485 (see chapter serial interfaces)
- 3 RS 232 (see chapter serial interfaces)
- 4 10 VDC power supply for external control devices (e.g remote panel)
- 5 Logic Outputs (see chapter logic outputs)
- 6 Logic Inputs (see chapter logic inputs)
- 7 Fault relay (See chapter fault relay)
- 8 ground connections (See chapter mass concept) max. cable section 4 mm²

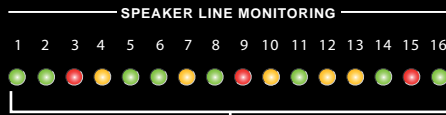

5

5 speaker line indication:

Standard (mode 0): yellow= line-detection error on this line
red= voice alarm running on this line

Pressing the info button:

Mode 1: indicates line state (LED No.16 blinking yellow)
green= Line is active,
red= Line is active and PriorityOnly

Mode2: indicates station ID (LED15 blinking yellow)
Binary code indication, 12 Bit (1=LSB, 12=MSB)

Mode3: indicates back-up status (LED14 blinking yellow)
green= normal mode,
red= back-up mode (back-up amplifier)

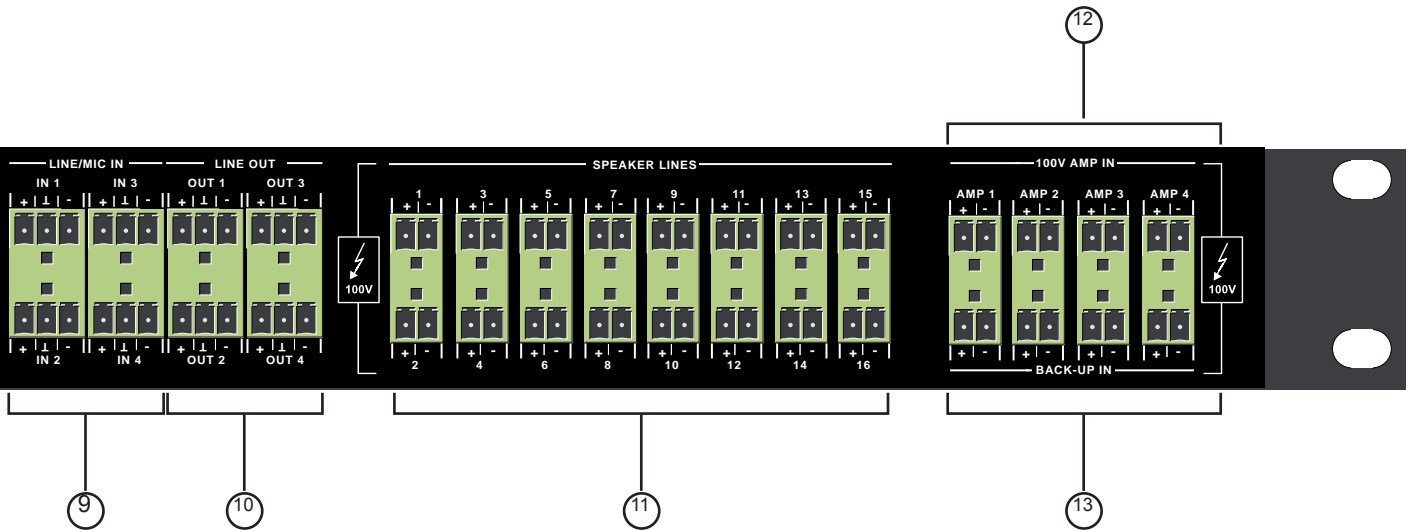

- 9 Mic/Line In (see chapter audio inputs)
- 10 Line Out (see chapter audio outputs)
- 11 Speaker lines: switched 100 Volt outputs connecting to the individual lines
- 12 100V line inputs of the amplifiers
- 13 100V line inputs of the back-up power amplifiers

Maximum cable section for all terminals 1.5 mm² - unless otherwise stated.

Block diagram DSP 1 (Main)

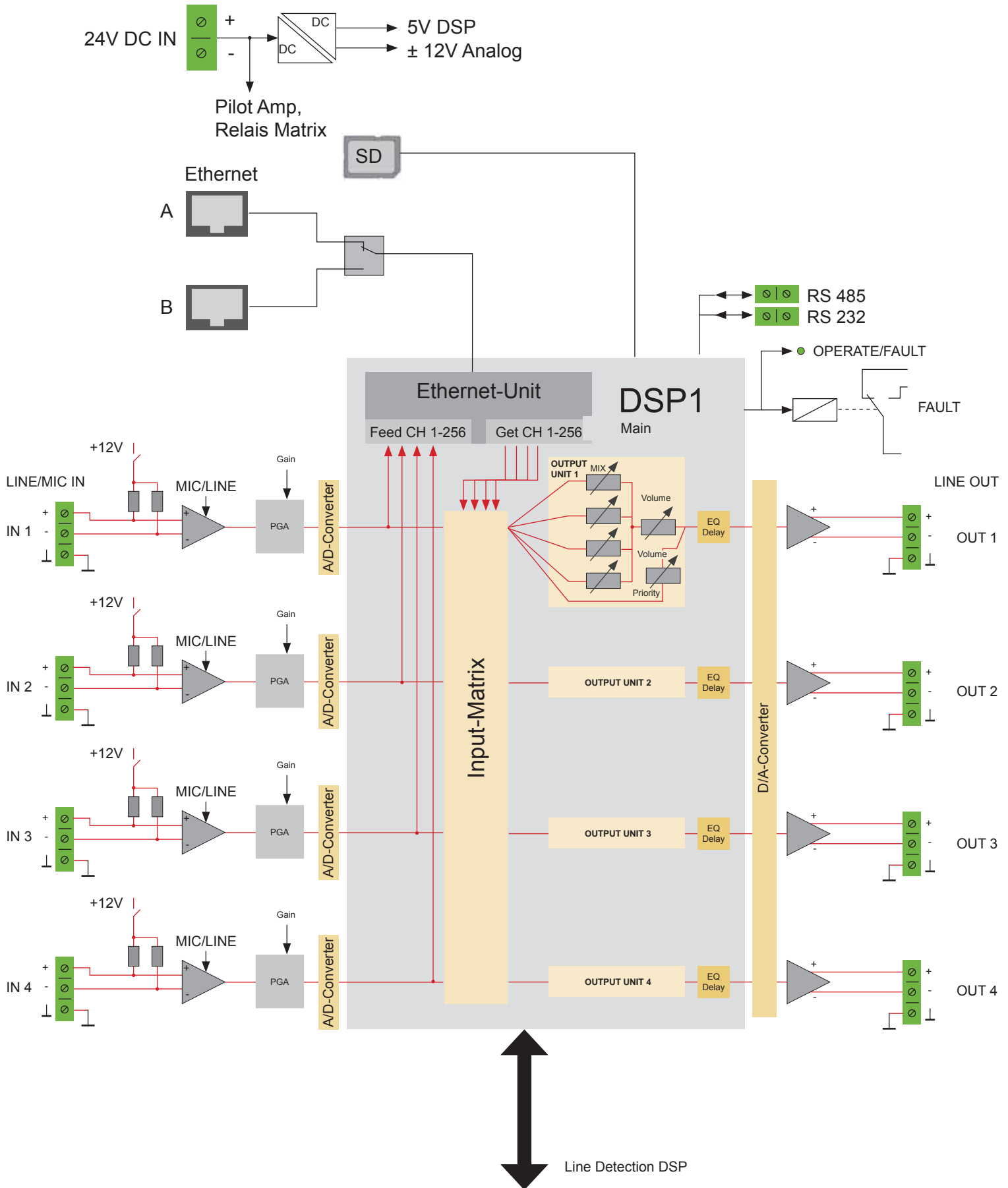

Block diagram DSP 2

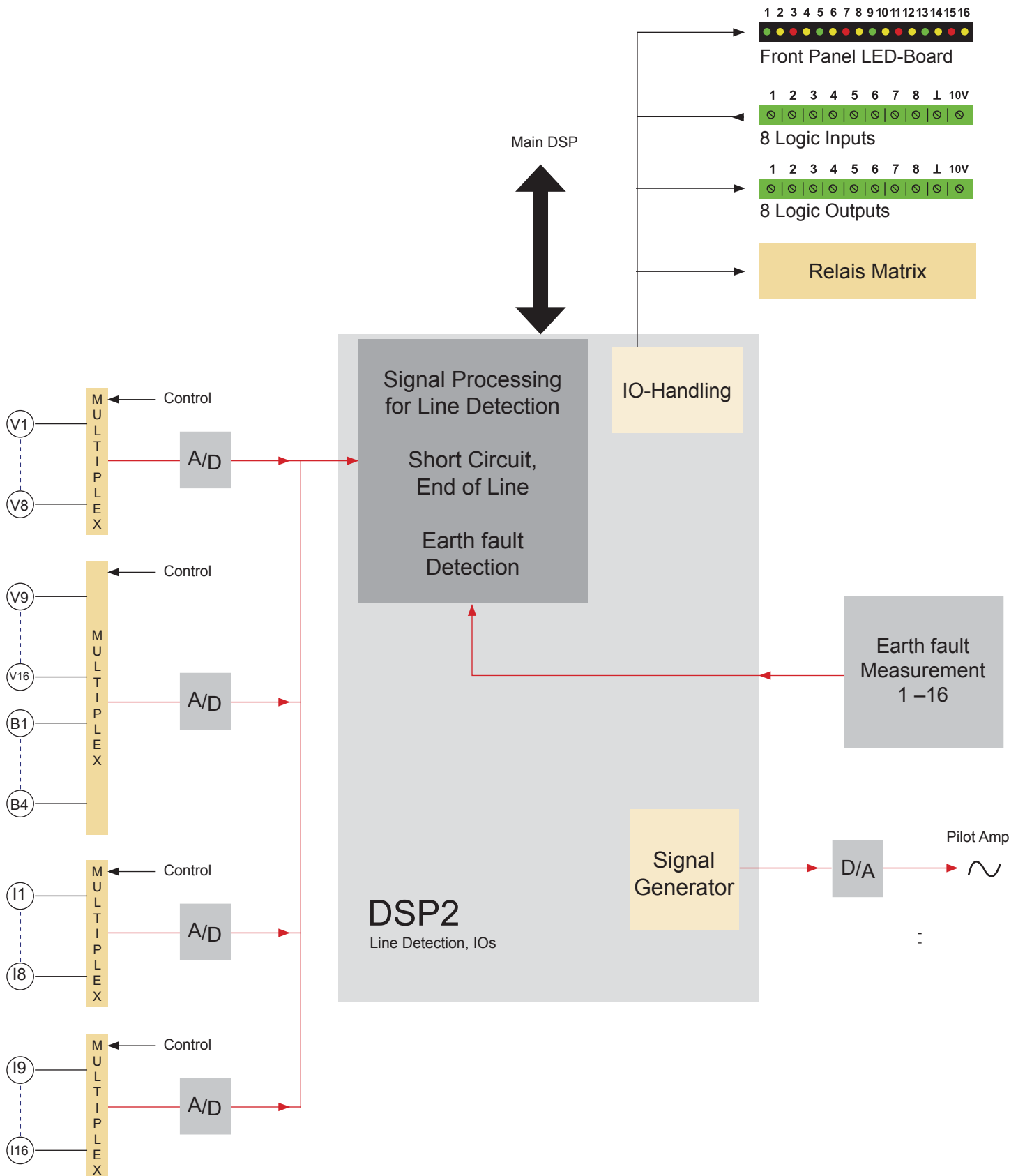

Signal-Routing

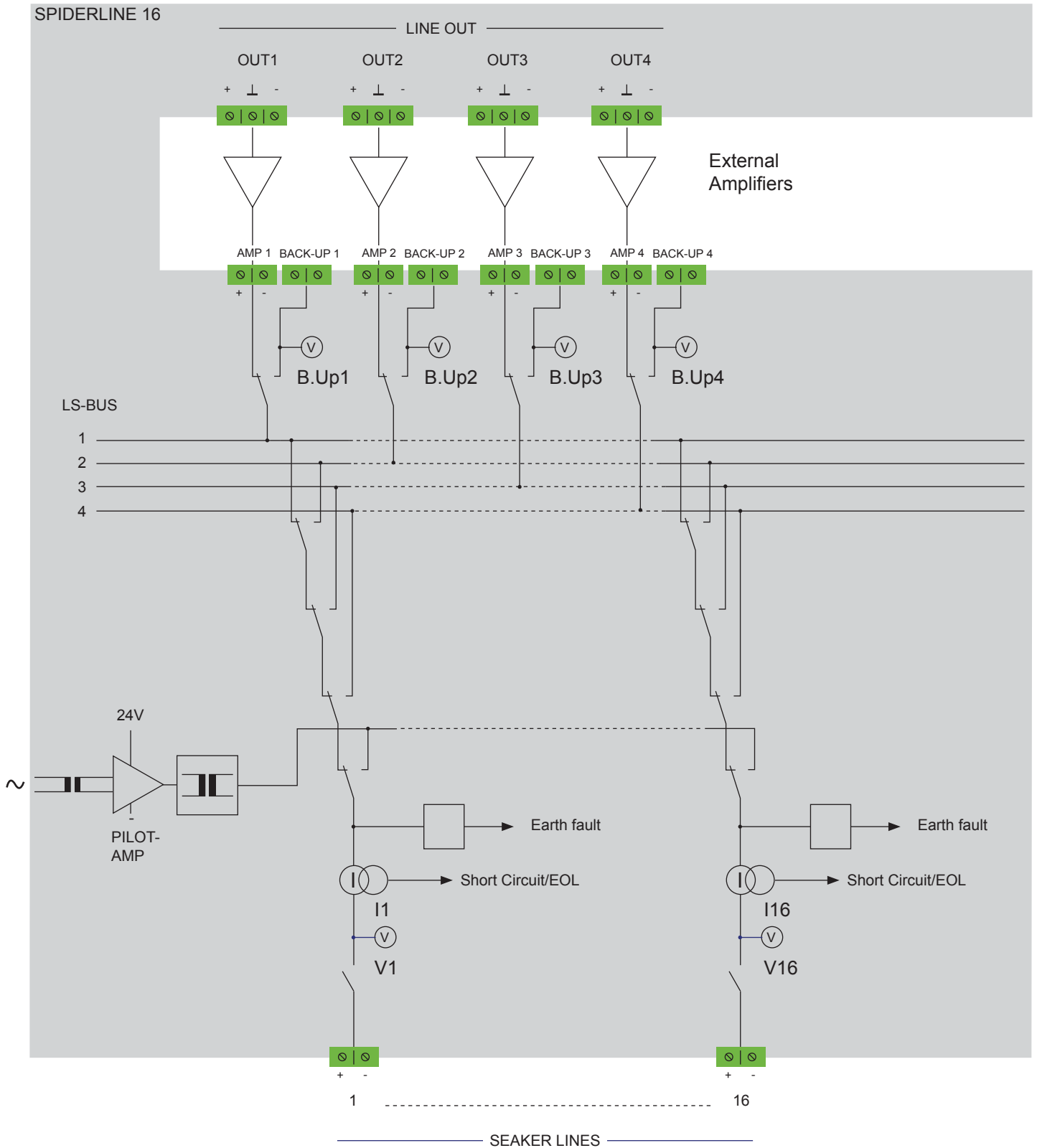

Power supply 24 V DC

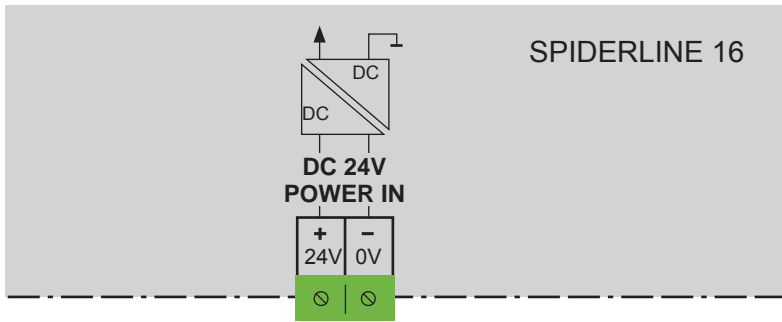

Connection is made to the included power adapter or an existing 24 V DC emergency power supply. The ground connection of the device (audio ground and ground of all digital audio interfaces) is electrically **not** connected to the negative pole of the DC supply. This is especially of importance, when a connection to peripheral 24 V emergency supplies is made, as the audio grounds, linked to power amplifiers or playback devices on site, are connected to the ground wire of the according sub-station. Due to the galvanic separation, loops and shunts can effectively be prevented. A floating guidance of the 24 V supply voltage or to ground at one spot, usually at the emergency power supply, is recommended.

Audio inputs

The device features 4 balanced inputs, which are XLR connectors on the rear cover. The maximum input gain is in line operation from -20 to +30 dB, in microphone operation from +10 to +60 dB for each channel selectable. Thus, all conventional microphones and media players can properly be adjusted. Phantom power is switchable per channel (12V).

Signal + ↓ - Signal



Audio outputs

The 4 outputs are balanced as well with XLR connectors on the rear cover. The maximum output level is +15 dB

Signal + ↓ - Signal



Digital inputs

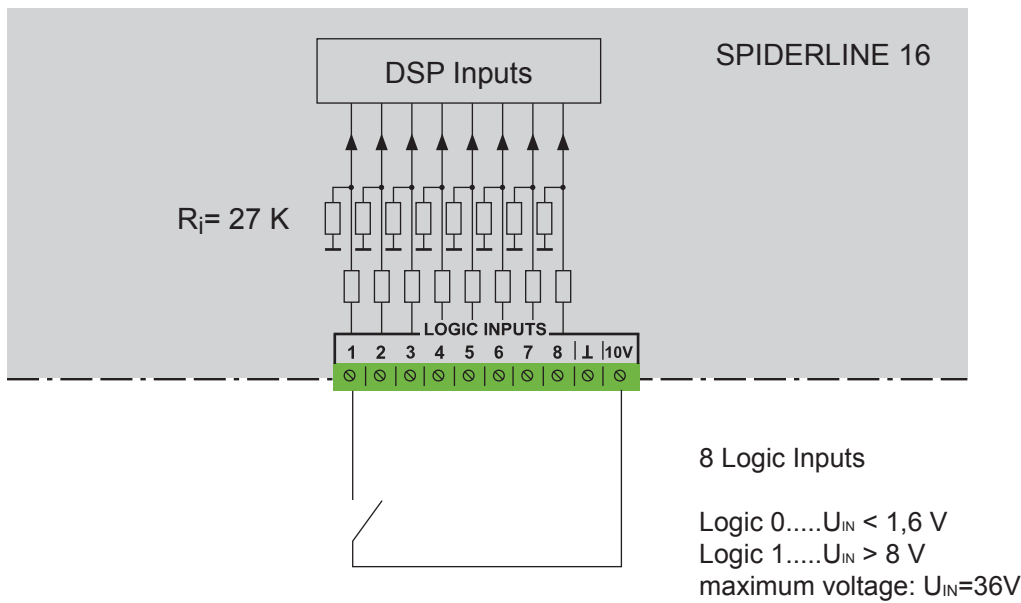

The device has 8 digital inputs, which are primarily designed for the detection of low-level operating and fault conditions. This includes the monitoring of fault signals of amplifiers, monitoring of cabinet temperature by thermostats, etc. A remote control, that is, an output follows at any point of the system the input is also possible. Each input state can be inverted for further processing by the software. For a complete overview of all features, see Software Manual „NetDesign“.

Digital outputs

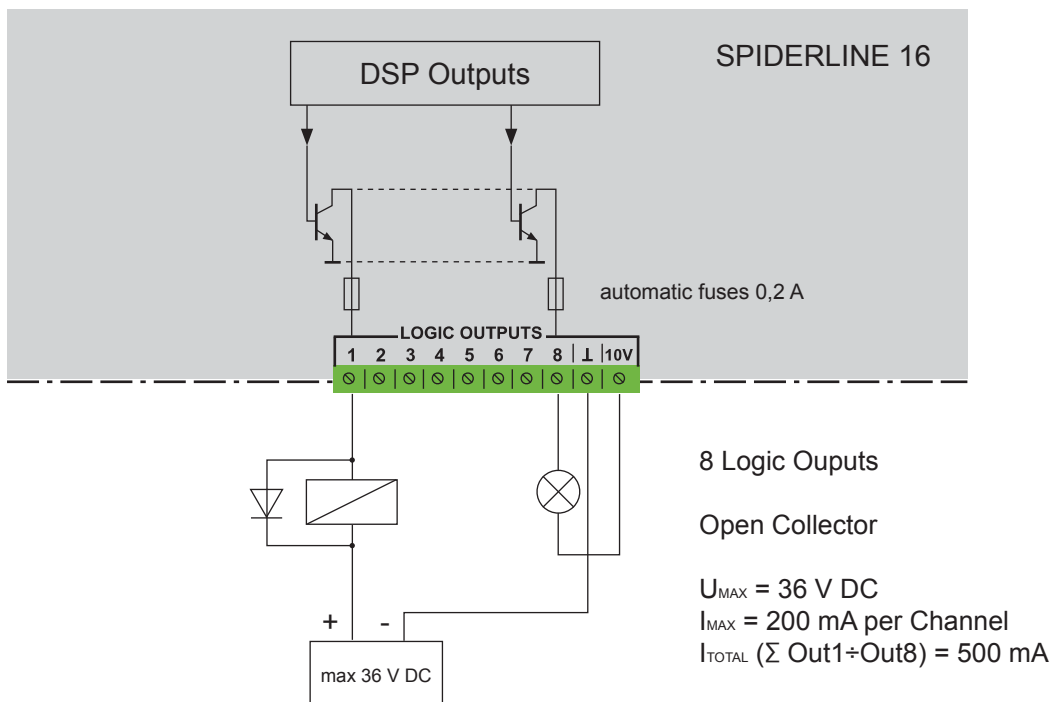

The device has 8 digital open collector transistor outputs. They are used for switching relays, lamps of lower power, etc. Typical applications are the display of faults, switching off other audio devices during an announcement and more.

The Serial interface

RS 232 and RS 485 are operated in parallel by the SpiderLine16. You may only connect one of the two interfaces at the same time.

RS 232

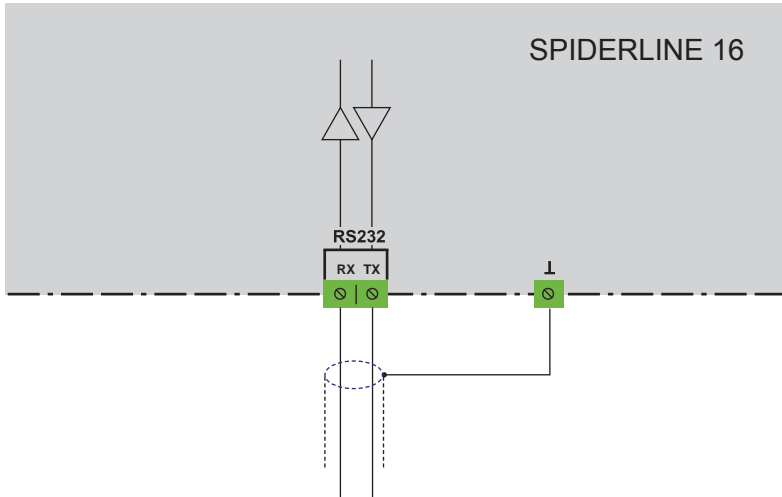

The RS 232 interface is used to connect control devices with a maximum cable length of up to 25m, such as media controls, management systems or indication systems, respectively for the export and logging of data.

RS 485

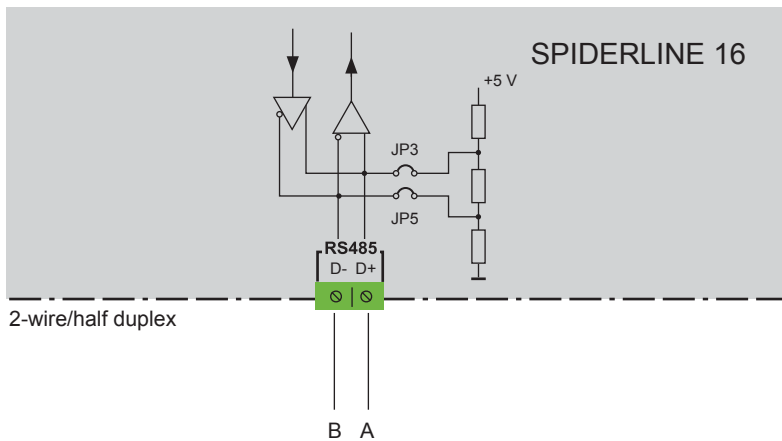

Operated in parallel with the RS 232 interface, to be used for up-mentioned functionalities, for distances of up to 500 meters of cable. With the RS 485 interface up to 16 devices can be connected in parallel (e.g. ITEC UP remote control panel).

Ethernet Interface

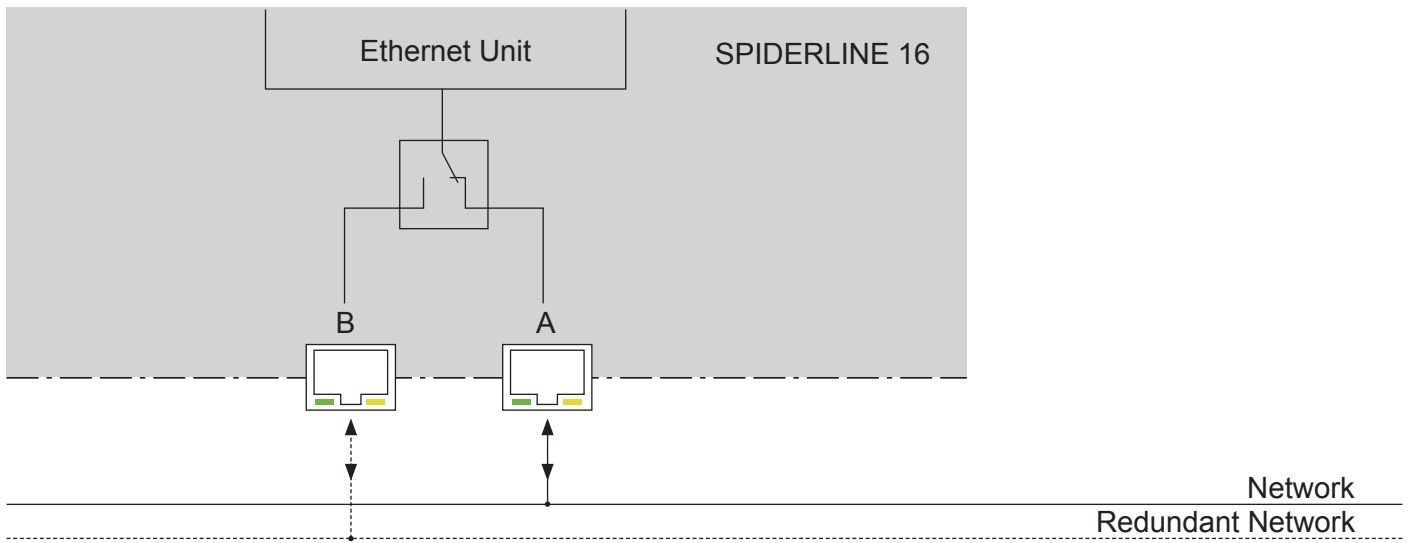

The network connection is carried out via socket A by default. If a link to second redundant network is planned, socket B is used. The LEDs on the RJ45 connector show the operating status of the network connection:

- Green LED on: Connected
- Green LED flashing: Connected and network activity
- Yellow LED on: valid connection (100Mbps full duplex)

Fault relay

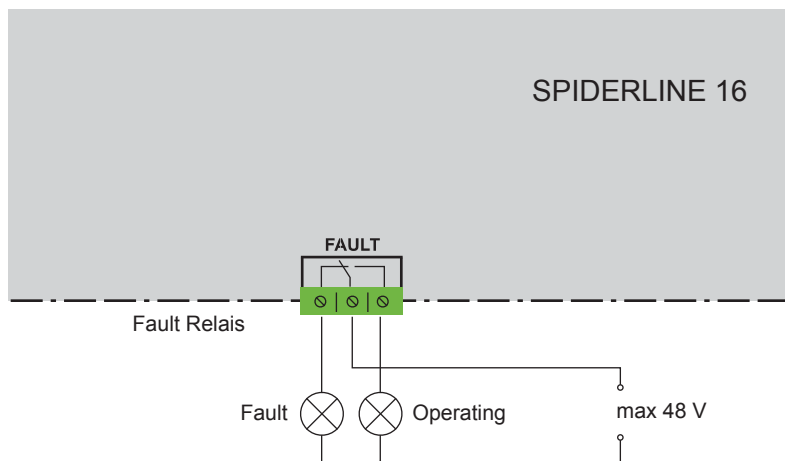

A potential-free relay contact used to display the operating status is available. In case the device is not operating or during a fault condition, the relay is released, during normal operation it is activated.

Mass concept

The SpiderLine 16 operates with three mass-potentials which might be referred to as one mass in a sense, but they are not interconnected. Thus, it is up to the wiring concept of the system if and where this masses are to be connected and/or are connected to the earth (ground) of the electric installation.

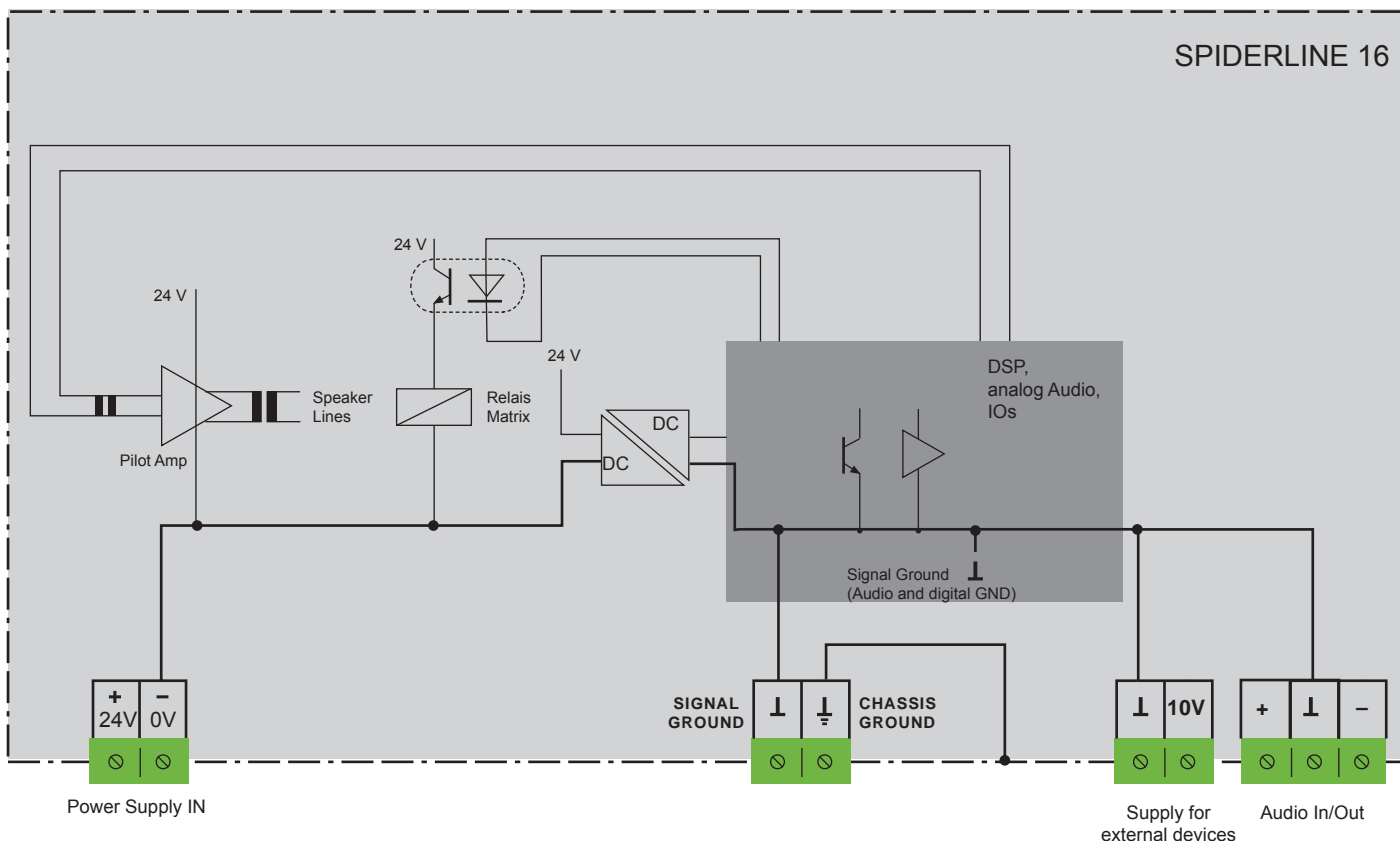

0 V: The negative pole of the supply voltage should be grounded to avoid ground loops and leakage currents at only one point with the system. The relevant standards and regulations must be observed.

Chasis Ground: is connected to the metal housing of the Spider16. Usually, this terminal should be connected with the cabinet or the grounding terminal of the cabinet.

Signal Ground: This Mass refers to all digital inputs and outputs, to the audio in- and outputs (Mic/Line In, Line Out) and the serial interfaces. Due to the internal use of DC/DC converters, audio transformers and opto-couplers this mass is not connected to the negative terminal of the 24VDC supply and housing (Chassis Ground).

Usually „Signal Ground“ gets the connection to the ground (earth) through the signal terminals of the power amplifiers or by connection to other systems and must/should not be connected separately.

SPIDERLINE 16/03 - TECHNICAL SPECIFICATIONS

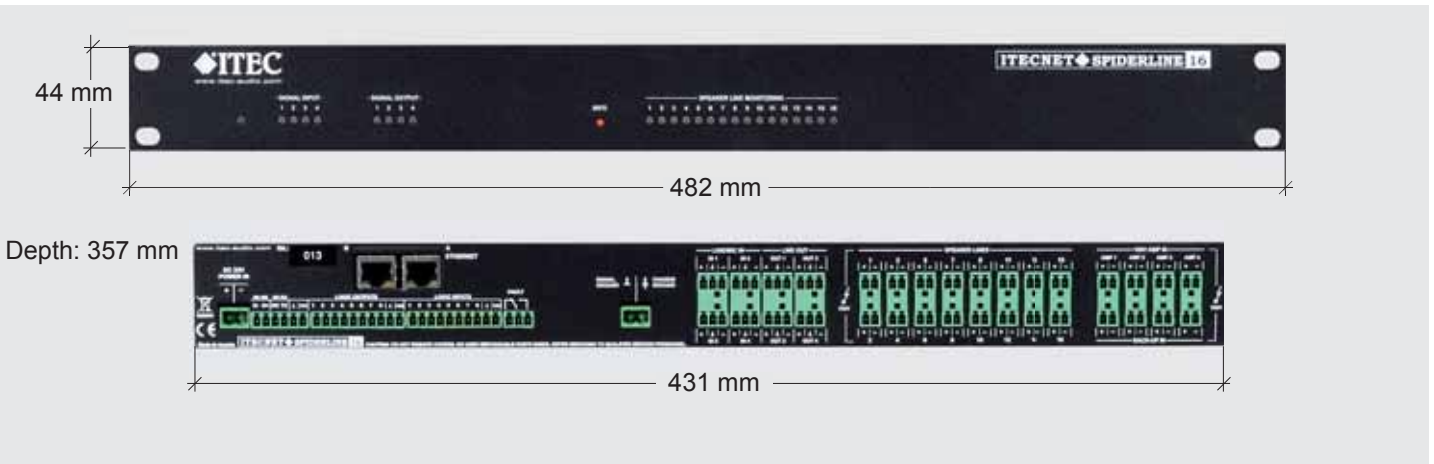

General	
External power supply	24 VDC (18 V < U < 32 V)
Current	ca. 500 mA without pilot tone and without applied load on the 10 VDC Voltage . With internal pilot-tone amplifier in operation, depending on impedance (power) of the connected speakers, up to 5 A.
Operating temperature	-5° C - +40° C
Dimensions	482 mm x 44 mm x 357 mm (W x H x D), 19" / 1 RU
Weight	8.5 kg
Audio	
Audio frequency response	40 Hz-20 kHz/-1 dB
Harmonic distortion (of Line-Outputs)	<0,005 %
General dynamics	103 dB
Balanced inputs	max. free selectable gain -20 dB to +60 dB
Phantom power	+12 V
Input impedance	6,6 kOhm
Balanced outputs	max. output level +15 dB, output impedance 300 Ohm
Sound Processing	
Per input	2-band fully parametric equalizer ± 15 dB, Q=0,1-70 1 low/high pass 1st order
Per output	4-band fully parametric equalizer ± 15 dB, delay: 0.023 ms-24.5 s bandpassfilter: 1st – 4th order
	Compressor/limiter
Filter quality	selectable from 0.1 to 70
Serial interfaces	
RS232 / RS485	9600, 19200, 57600, 115.200 baud
Digital inputs	8 schmitt-trigger inputs on plug in-terminal strip
Input voltage	Low < 1,6 V / High > 8 V
Max. allowable voltage	36 V
Input current (@10 V)	ca. 0,5 mA @ 12 V, ca. 1 mA @ 24 V
Digital outputs	8 open-collector outputs on plug in-terminal strip
Max. voltage	36 V
Max. current	200 mA per output / total 500 mA (sum of all outputs switched))
Dry contact alarm relay	
Max. voltage / max. switching power	48 VAC/DC / 500 mA
Network	Ethernet 100 Base-TX, IEEE 802.3u

All informations without guarantee, Specifications subject to technical changes.



ITEC- Tontechnik und Industrieelektronik GesmbH, A-8200 Lassnitzthal 300
Tel.: +43 (0)3133 / 3780-0, office@itec-audio.com, www.itec-audio.com