

## USER MANUAL

### MODEL:

VP-428H2

4K HDBT Transmitter/Scaler



# Contents

|   |           |
|---|-----------|
| <b>Introduction</b>                                 | <b>1</b>  |
| Getting Started                                     | 1         |
| Overview  | 2         |
| Functionality                                       | 2         |
| Typical Applications                                | 4         |
| Controlling your VP-428H2                           | 4         |
| <b>Defining VP-428H2 4K HDBT Transmitter/Scaler</b> | <b>5</b>  |
| <b>Connecting VP-428H2</b>                          | <b>7</b>  |
| Connecting to VP-428H2 via RS-232                   | 8         |
| <b>Operating VP-428H2</b>                           | <b>9</b>  |
| Front Panel Buttons                                 | 9         |
| OSD Menu  | 9         |
| <b>Firmware Upgrade</b>                             | <b>14</b> |
| <b>Technical Specifications</b>                     | <b>15</b> |
| Default Communication Parameters                    | 16        |
| Input Resolutions                                   | 16        |
| Output Resolutions                                  | 17        |
| <b>Protocol 3000</b>                                | <b>18</b> |
| Understanding Protocol 3000                         | 19        |
| Kramer Protocol 3000 Syntax                         | 20        |
| Protocol 3000 Commands                              | 21        |

# Introduction

Welcome to Kramer Electronics! Since 1981, Kramer Electronics has been providing a world of unique, creative, and affordable solutions to the vast range of problems that confront the video, audio, presentation, and broadcasting professional on a daily basis. In recent years, we have redesigned and upgraded most of our line, making the best even better!

Our 1,000-plus different models now appear in 15 groups that are clearly defined by function: GROUP 1: Distribution Amplifiers; GROUP 2: Switchers and Routers; GROUP 3: Control Systems; GROUP 4: Format & Standards Converters; GROUP 5: Range Extenders & Repeaters; GROUP 6: Specialty AV Products; GROUP 7: Scalers; GROUP 8: Cables and Connectors; GROUP 9: Room Connectivity; GROUP 10: Mounting and Rack Adapters; GROUP 11: Sierra Video; GROUP 12: Digital Signage; GROUP 13: Audio; GROUP 14: Collaboration; and GROUP 15: KM & KVM Switches.

---

## Getting Started

We recommend that you:

- Unpack the equipment carefully and save the original box and packaging materials for possible future shipment.
- Review the contents of this user manual.



Go to [www.kramerav.com/downloads/VP-428H2](http://www.kramerav.com/downloads/VP-428H2) to check for up-to-date user manuals, application programs, and to check if firmware upgrades are available (where appropriate).

## Achieving the Best Performance

- Use only good quality connection cables (we recommend Kramer high-performance, high-resolution cables) to avoid interference, deterioration in signal quality due to poor matching, and elevated noise levels (often associated with low quality cables).
- Do not secure the cables in tight bundles or roll the slack into tight coils.
- Avoid interference from neighbouring electrical appliances that may adversely influence signal quality.
- Position your Kramer **VP-428H2** away from moisture, excessive sunlight and dust.



This equipment is to be used only inside a building. It may only be connected to other equipment that is installed inside a building.

## Safety Instructions



- Caution: There are no operator serviceable parts inside the unit.
- Warning: Use only the Kramer Electronics power supply that is provided with the unit.
- Warning: Disconnect the power and unplug the unit from the wall before installing.

## Recycling Kramer Products

The Waste Electrical and Electronic Equipment (WEEE) Directive 2002/96/EC aims to reduce the amount of WEEE sent for disposal to landfill or incineration by requiring it to be collected and recycled. To comply with the WEEE Directive, Kramer Electronics has made arrangements with the European Advanced Recycling Network (EARN) and will cover any costs of treatment, recycling and recovery of waste Kramer Electronics branded equipment on arrival at the EARN facility. For details of Kramer's recycling arrangements in your particular country go to our recycling pages at [www.kramerav.com/support/recycling](http://www.kramerav.com/support/recycling).

---

## Overview

Congratulations on purchasing your Kramer **VP-428H2 4K HDBT Transmitter/Scaler**.

**VP-428H2** is an HDBaseT 4K transmitter/scaler with HDMI, DP and VGA inputs. **VP-428H2** supports HDBT tunneling of Ethernet, bidirectional RS-232 and IR signals, as well as PoE to provide power to the HDBaseT receiver. It receives the selected AV signal, up-scales, down-scales or bypasses the video, according to the settings selected by the user, and converts it for sending via HDBaseT, together with the tunneled data and PoE.

**VP-428H2** is housed in a compact, Kramer MegaTOOL™ enclosure which can be mounted side by side in a 19-inch rack using the **RK-T2B** rack adapter.

**VP-428H2** provides exceptional quality, advanced and user-friendly operation, and flexible control.

---

## Functionality

- Supports scaling to / from all input and output resolutions.
- Works with any HDBT receiver (supports 4K without the need for a specialized receiver).
- Upscales to all popular 4K resolutions (to 4K60 4:2:0 max).
- Downscales from 4K60 4:4:4 to all resolutions.
- Automatically downscales 6G 4K color space to 4:2:0.
- 4K resolution bypass option, supporting HDR.
- HDBT tunnelling of RS-232, IR and Ethernet.

## Exceptional Quality

- PixPerfect™ Scaling Technology – Kramer’s precision pixel mapping and high quality scaling technology.
- Output resolutions – with selectable refresh rates up to 4K/UHD.
- System Range – For the HDBaseT output, extended reach of up to 100m (330ft) using Kramer recommended cables.
- Includes numerous filters and algorithms for eliminating picture artifacts.
- HDCP 2.2, HDMI 2.0/1.4 compliance.
- HDBaseT certified.

## Advanced and User-friendly Operation

- Built-in video Proc-Amp – color, hue, sharpness, contrast, and brightness are set individually for each input.
- An OSD (On-Screen Display) – for making adjustments – that can be located anywhere on the screen.
- Advanced EDID management per input.
- Constant Sync – Maintains sync on the output, even if input video signal is lost or interrupted.
- Audio – Unbalanced stereo and embedded audio inputs.
- Audio delay selection.
- MENU and navigation buttons for using OSD.
- Front-panel push-button for input selection.
- STEP-IN button for Step-in control when connected to a device that provides step-in support.
- Firmware Upgrade – Via USB-A port, using a user-friendly software upgrade tool.
- Auto-switching – Selectable last connected and auto-scanning of inputs.
- Non-volatile memory that retains the last settings, after switching the power off and then on again.

## Flexible Connectivity

- A FREEZE button, RESET TO XGA/1080P buttons (to hardware-reset the output resolution); and a STEP-IN button.
- 3 video input ports – DP, HDMI and PC.
- Ethernet tunnelling via HDBT.
- Analog stereo audio input.
- Embedded audio on the HDMI and DisplayPort inputs and outputs.
- Scaled HDBT output.
- IR input and output ports.
- Data and device control RS-232 ports.

---

## Typical Applications

VP-428H2 is ideal for the following typical applications:

- Educational – Classrooms, lecture theaters.
- Projection systems in conference rooms, boardrooms, hotels and churches.
- Home theatre up-scaling.

---

## Controlling your VP-428H2

Control your VP-428H2 directly via the front panel push buttons (see [Front Panel Buttons](#) on page [9](#)), with on-screen menus ([OSD Menu](#) on page [9](#)), or:

- By RS-232 serial commands transmitted by a touch screen system, PC, or other serial controller (see [Connecting to VP-428H2 via RS-232](#) on page [8](#)).

# Defining VP-428H2 4K HDBT Transmitter/Scaler

This section defines VP-428H2.

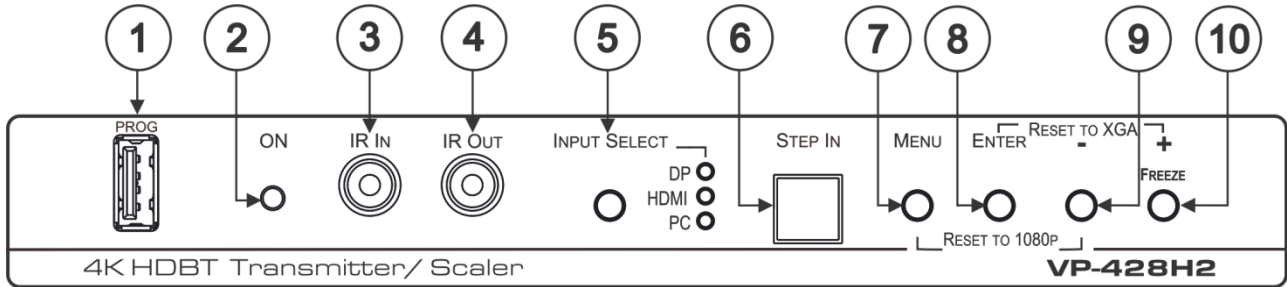

Figure 1: VP-428H2 4K HDBT Transmitter/Scaler Front Panel

| # | Feature                | Function  |
|---|------------------------|---|
| ① | PROG USB Connector     | Connects to a USB memory stick for programming upgrade.   |
| ② | ON LED                 | Lights green when the unit is powered on.   |
| ③ | IR IN 3.5mm Mini Jack  | Connects to an IR sensor.   |
| ④ | IR OUT 3.5mm Mini Jack | Connects to an IR emitter.  |
| ⑤ | INPUT SELECT Button    | Press to cycle between inputs.  |
|   | INPUT SELECT LEDs      | The selected input lights.  |
| ⑥ | STEP IN Button         | Press to activate the input on the switcher to which the <b>VP-428H2</b> is connected.  |
| ⑦ | MENU Button            | Press to enter/exit the on-screen display (OSD) menu.<br>Press together with the – button to reset to 1080p.                      |
| ⑧ | ENTER Button           | In OSD, press to choose the highlighted menu item.<br>Press together with the +/FREEZE button to reset to XGA.                    |
| ⑨ | – Button               | In OSD, press to move back through the list or to decrement the parameter value.  |
| ⑩ | + /FREEZE Button       | In OSD, press to move forward through the list or to increment the parameter value. When not in OSD, press to freeze the display. |

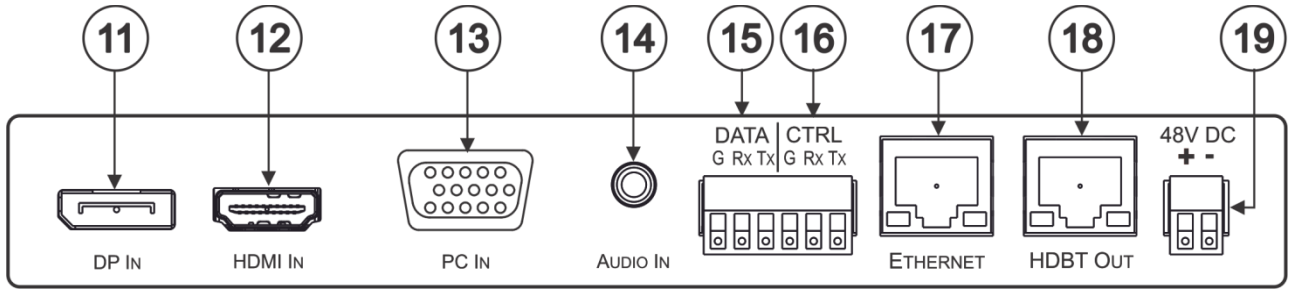

Figure 2: VP-428H2 4K HDBT Transmitter/Scaler Rear Panel

| #  | Feature                                    | Function  |
|----|--|---|
| 11 | DP IN DisplayPort Connector                | Connect to a DisplayPort source.                                  |
| 12 | HDMI IN Connector                          | Connect to an HDMI source.  |
| 13 | PC IN 15-pin HD Connector                  | Connect to a computer graphics source.                            |
| 14 | AUDIO IN 3.5mm Mini Jack                   | Connects to an unbalanced stereo audio source.                    |
| 15 | DATA (G, Rx, Tx) Terminal Block Connectors | Connect to a source for tunneling control commands via HDBaseT.   |
| 16 | CTRL (G, Rx, Tx) Terminal Block Connectors | Connect to a PC or remote controller to control <b>VP-428H2</b> . |
| 17 | ETHERNET RJ-45 Connector                   | Connect to a PC via a LAN to tunnel Ethernet data via HDBT.       |
| 18 | HDBT OUT RJ-45 Connector                   | Connect to an HDBaseT receiver.                                   |
| 19 | 48V DC Power Terminal Block Connector      | Connect to the Kramer power adapter.                              |

# Connecting VP-428H2



Always switch off the power to each device before connecting it to your **VP-428H2**. After connecting your **VP-428H2**, connect its power and then switch on the power to each device.

To connect **VP-428H2** as illustrated in the example in [Figure 3](#):

1. Connect a DP source (for example, a laptop) to the DP IN DisplayPort connector (11).
2. Connect an HDMI source (for example, a Blu-ray player) to the HDMI IN connector (12).
3. Connect a computer graphics source (for example, a laptop) to the PC IN 15-pin HD connector (13).
4. Connect an analog stereo audio source (for example, from the laptop) to the AUDIO IN 3.5mm mini jack (14).
5. Connect the HDBT OUT RJ-45 port (18) to a receiver (for example, the Kramer **TP-580Rxr**).
6. Connect an IR sensor to the IR IN 3.5mm mini jack (3) (for example, to control the projector connected to the HDBT receiver that is connected to HDBT OUT (18)). The projector IR remote control transmitter sends commands to the projector via the IR sensor.
7. Connect the IR IN 3.5mm mini jack to an IR emitter (for example, to control the HDMI-connected Blu-ray player via the HDBT receiver that is connected to HDBT OUT (18)).
8. Connect a control system to the CTRL (G, Rx, Tx) terminal block connectors (16) to control **VP-428H2**.
9. Connect a control system to the DATA (G, Rx, Tx) terminal block connectors (15) to tunnel control commands via HDBT OUT.
10. Connect the RJ-45 Ethernet port (17) to tunnel Ethernet data via HDBT OUT.
11. Connect the 48V power adapter (19) and connect the adapter to the mains.

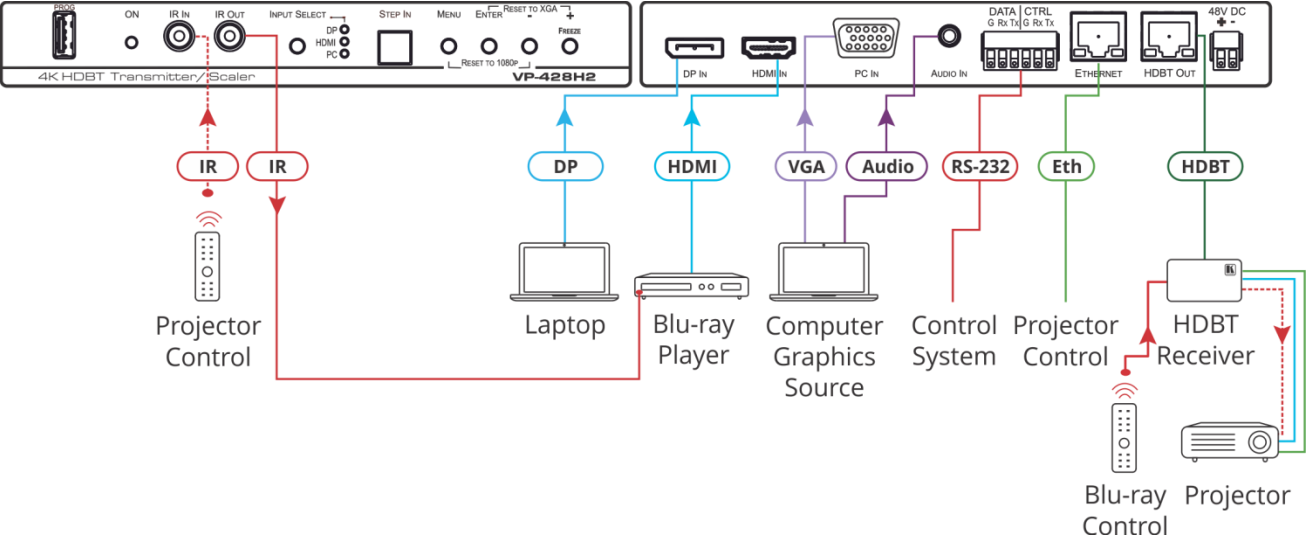

Figure 3: Connecting to the VP-428H2

### Connecting to VP-428H2 via RS-232

You can connect to the VP-428H2 via an RS-232 connection (15, 16) using, for example, a PC.

To connect to the VP-428H2 via RS-232 Connect the RS-232 rear panel port on the VP-428H2 unit to the RS-232 port on your PC.

# Operating VP-428H2

Operate **VP-428H2** via:

- [Front Panel Buttons](#) on page [9](#).
- [OSD Menu](#) on page [9](#).

---

## Front Panel Buttons

Use **VP-428H2** front panel buttons to perform the following operations:

- Press **MENU** (7), **ENTER** (8), **+** (10) and **-** (9) to use the OSD menu.
- Press **MENU** and **-** simultaneously to reset the resolution to 1080p (RESET TO 1080p).
- Press **ENTER** and **FREEZE** (10) simultaneously to reset the resolution to XGA (RESET TO XGA).
- Press **INPUT SELECT** (5) to manually select the input to switch to the output.
- Press **STEP-IN** (6) to activate the input on a Step-in compatible device, see [Using the Step-in Feature](#) on page [13](#).

---

## OSD Menu

The control buttons let you control the **VP-428H2** via the OSD menu. Press:

- **MENU** to enter the menu.  
The default timeout is set to 10 seconds.
- **ENTER** button to accept changes and to change the menu settings.
- **+** and **-** to move through the OSD menu, which is displayed on the video output.

On the OSD menu, select **EXIT** to exit the menu.

The OSD menu enables performing the following:

- [Setting Image Parameters](#) on page [10](#).
- [Selecting the Input Signal](#) on page [10](#).
- [Setting Output Parameters](#) on page [11](#).
- [Setting the Audio Source](#) on page [11](#).
- [Setting OSD Parameters](#) on page [12](#).
- [Defining Advanced Settings](#) on page [12](#).
- [Performing Factory Reset](#) on page [13](#).
- [Viewing Device Information](#) on page [13](#).

## Setting Image Parameters

To set the image parameters:

1. On the front panel click **MENU**. The menu appears.
2. Click **PICTURE** and set the following:

| Menu Item                               | Function  |   |
|---|---|---|
| CONTRAST                                | Set the contrast (the range and default values vary according to the input signal).   |   |
| BRIGHTNESS                              | Set the brightness (the range and default values vary according to the input signal). |   |
| FINETUNE                                | <b>Input Signal</b>   | <b>Function</b>   |
|   | HDMI/DP   | HUE – set the color hue.  |
|   |   | SATURATION – set the color saturation.  |
|   |   | SHARPNESS – set the sharpness of the picture.   |
|   |   | NOISE REDUCTION – select the noise reduction: OFF (default), LOW, MIDDLE, HIGH or AUTO. |
|   | VGA   | PHASE – set the phase.  |
|   |   | CLOCK – set the clock.  |
|   |   | H-POSITION – set the horizontal position.   |
| V-POSITION – set the vertical position. |   |   |
| COLOR                                   | Set the RED, GREEN and BLUE shades.   |   |

## Selecting the Input Signal

To set the input source:

1. On the front panel click **MENU**. The menu appears.
2. Click **INPUT** and set select the input source: DP, HDMI or PC (default).

## Setting Output Parameters

To set the output parameters:

1. On the front panel click **MENU**. The menu appears.
2. Click **PICTURE** and set the following:

| Menu Item       | Function   |              |                   |            |                   |          |      |         |         |          |      |         |         |             |           |          |          |             |           |          |          |              |            |          |          |              |            |          |          |              |            |          |          |              |            |           |           |              |            |          |          |         |           |           |           |         |           |           |           |         |           |           |           |              |                  |           |           |              |                  |              |              |
|-----------------|--|--------------|-------------------|------------|-------------------|----------|------|---------|---------|----------|------|---------|---------|-------------|-----------|----------|----------|-------------|-----------|----------|----------|--------------|------------|----------|----------|--------------|------------|----------|----------|--------------|------------|----------|----------|--------------|------------|-----------|-----------|--------------|------------|----------|----------|---------|-----------|-----------|-----------|---------|-----------|-----------|-----------|---------|-----------|-----------|-----------|--------------|------------------|-----------|-----------|--------------|------------------|--------------|--------------|
| SIZE            | Set the size of the image: FULL, OVER SCAN, UNDERSCAN, LETTER BOX, PAN SCAN or BEST FIT.   |              |                   |            |                   |          |      |         |         |          |      |         |         |             |           |          |          |             |           |          |          |              |            |          |          |              |            |          |          |              |            |          |          |              |            |           |           |              |            |          |          |         |           |           |           |         |           |           |           |         |           |           |           |              |                  |           |           |              |                  |              |              |
| 4K in -> 4K out | Select SCALER to process the 4K-in to 4K-out signal via the scaler.<br>Select BYPASS to bypass the scaler.   |              |                   |            |                   |          |      |         |         |          |      |         |         |             |           |          |          |             |           |          |          |              |            |          |          |              |            |          |          |              |            |          |          |              |            |           |           |              |            |          |          |         |           |           |           |         |           |           |           |         |           |           |           |              |                  |           |           |              |                  |              |              |
| RESOLUTION      | Select the output resolution:  |              |                   |            |                   |          |      |         |         |          |      |         |         |             |           |          |          |             |           |          |          |              |            |          |          |              |            |          |          |              |            |          |          |              |            |           |           |              |            |          |          |         |           |           |           |         |           |           |           |         |           |           |           |              |                  |           |           |              |                  |              |              |
|                 | <table border="1"> <thead> <tr> <th>Appears as</th> <th>Output Resolution</th> <th>Appears as</th> <th>Output Resolution</th> </tr> </thead> <tbody> <tr> <td>720X480P</td> <td>480p</td> <td>640x480</td> <td>640x480</td> </tr> <tr> <td>720X576P</td> <td>576p</td> <td>800x600</td> <td>800x600</td> </tr> <tr> <td>1280X720P50</td> <td>720p@50Hz</td> <td>1024x768</td> <td>1024x768</td> </tr> <tr> <td>1280X720P60</td> <td>720p@60Hz</td> <td>1280x768</td> <td>1280x768</td> </tr> <tr> <td>1920X1080P24</td> <td>1080p@24Hz</td> <td>1360x768</td> <td>1360x768</td> </tr> <tr> <td>1920X1080P25</td> <td>1080p@25Hz</td> <td>1280x720</td> <td>1280x720</td> </tr> <tr> <td>1920X1080P30</td> <td>1080p@30Hz</td> <td>1280x800</td> <td>1280x800</td> </tr> <tr> <td>1920X1080P50</td> <td>1080p@50Hz</td> <td>1280x1024</td> <td>1280x1024</td> </tr> <tr> <td>1920X1080P60</td> <td>1080p@60Hz</td> <td>1440x900</td> <td>1440x900</td> </tr> <tr> <td>4K2K 24</td> <td>4K2K@24Hz</td> <td>1400x1050</td> <td>1400x1050</td> </tr> <tr> <td>4K2K 25</td> <td>4K2K@25Hz</td> <td>1920X1080</td> <td>1920X1080</td> </tr> <tr> <td>4K2K 30</td> <td>4K2K@30Hz</td> <td>1680x1050</td> <td>1680x1050</td> </tr> <tr> <td>4K2K(420) 50</td> <td>4K2K@50Hz(4:2:0)</td> <td>1600x1200</td> <td>1600x1200</td> </tr> <tr> <td>4K2K(420) 60</td> <td>4K2K@60Hz(4:2:0)</td> <td>1920x1200 RB</td> <td>1920x1200 RB</td> </tr> </tbody> </table> | Appears as   | Output Resolution | Appears as | Output Resolution | 720X480P | 480p | 640x480 | 640x480 | 720X576P | 576p | 800x600 | 800x600 | 1280X720P50 | 720p@50Hz | 1024x768 | 1024x768 | 1280X720P60 | 720p@60Hz | 1280x768 | 1280x768 | 1920X1080P24 | 1080p@24Hz | 1360x768 | 1360x768 | 1920X1080P25 | 1080p@25Hz | 1280x720 | 1280x720 | 1920X1080P30 | 1080p@30Hz | 1280x800 | 1280x800 | 1920X1080P50 | 1080p@50Hz | 1280x1024 | 1280x1024 | 1920X1080P60 | 1080p@60Hz | 1440x900 | 1440x900 | 4K2K 24 | 4K2K@24Hz | 1400x1050 | 1400x1050 | 4K2K 25 | 4K2K@25Hz | 1920X1080 | 1920X1080 | 4K2K 30 | 4K2K@30Hz | 1680x1050 | 1680x1050 | 4K2K(420) 50 | 4K2K@50Hz(4:2:0) | 1600x1200 | 1600x1200 | 4K2K(420) 60 | 4K2K@60Hz(4:2:0) | 1920x1200 RB | 1920x1200 RB |
| Appears as      | Output Resolution  | Appears as   | Output Resolution |            |                   |          |      |         |         |          |      |         |         |             |           |          |          |             |           |          |          |              |            |          |          |              |            |          |          |              |            |          |          |              |            |           |           |              |            |          |          |         |           |           |           |         |           |           |           |         |           |           |           |              |                  |           |           |              |                  |              |              |
| 720X480P        | 480p   | 640x480      | 640x480           |            |                   |          |      |         |         |          |      |         |         |             |           |          |          |             |           |          |          |              |            |          |          |              |            |          |          |              |            |          |          |              |            |           |           |              |            |          |          |         |           |           |           |         |           |           |           |         |           |           |           |              |                  |           |           |              |                  |              |              |
| 720X576P        | 576p   | 800x600      | 800x600           |            |                   |          |      |         |         |          |      |         |         |             |           |          |          |             |           |          |          |              |            |          |          |              |            |          |          |              |            |          |          |              |            |           |           |              |            |          |          |         |           |           |           |         |           |           |           |         |           |           |           |              |                  |           |           |              |                  |              |              |
| 1280X720P50     | 720p@50Hz  | 1024x768     | 1024x768          |            |                   |          |      |         |         |          |      |         |         |             |           |          |          |             |           |          |          |              |            |          |          |              |            |          |          |              |            |          |          |              |            |           |           |              |            |          |          |         |           |           |           |         |           |           |           |         |           |           |           |              |                  |           |           |              |                  |              |              |
| 1280X720P60     | 720p@60Hz  | 1280x768     | 1280x768          |            |                   |          |      |         |         |          |      |         |         |             |           |          |          |             |           |          |          |              |            |          |          |              |            |          |          |              |            |          |          |              |            |           |           |              |            |          |          |         |           |           |           |         |           |           |           |         |           |           |           |              |                  |           |           |              |                  |              |              |
| 1920X1080P24    | 1080p@24Hz   | 1360x768     | 1360x768          |            |                   |          |      |         |         |          |      |         |         |             |           |          |          |             |           |          |          |              |            |          |          |              |            |          |          |              |            |          |          |              |            |           |           |              |            |          |          |         |           |           |           |         |           |           |           |         |           |           |           |              |                  |           |           |              |                  |              |              |
| 1920X1080P25    | 1080p@25Hz   | 1280x720     | 1280x720          |            |                   |          |      |         |         |          |      |         |         |             |           |          |          |             |           |          |          |              |            |          |          |              |            |          |          |              |            |          |          |              |            |           |           |              |            |          |          |         |           |           |           |         |           |           |           |         |           |           |           |              |                  |           |           |              |                  |              |              |
| 1920X1080P30    | 1080p@30Hz   | 1280x800     | 1280x800          |            |                   |          |      |         |         |          |      |         |         |             |           |          |          |             |           |          |          |              |            |          |          |              |            |          |          |              |            |          |          |              |            |           |           |              |            |          |          |         |           |           |           |         |           |           |           |         |           |           |           |              |                  |           |           |              |                  |              |              |
| 1920X1080P50    | 1080p@50Hz   | 1280x1024    | 1280x1024         |            |                   |          |      |         |         |          |      |         |         |             |           |          |          |             |           |          |          |              |            |          |          |              |            |          |          |              |            |          |          |              |            |           |           |              |            |          |          |         |           |           |           |         |           |           |           |         |           |           |           |              |                  |           |           |              |                  |              |              |
| 1920X1080P60    | 1080p@60Hz   | 1440x900     | 1440x900          |            |                   |          |      |         |         |          |      |         |         |             |           |          |          |             |           |          |          |              |            |          |          |              |            |          |          |              |            |          |          |              |            |           |           |              |            |          |          |         |           |           |           |         |           |           |           |         |           |           |           |              |                  |           |           |              |                  |              |              |
| 4K2K 24         | 4K2K@24Hz  | 1400x1050    | 1400x1050         |            |                   |          |      |         |         |          |      |         |         |             |           |          |          |             |           |          |          |              |            |          |          |              |            |          |          |              |            |          |          |              |            |           |           |              |            |          |          |         |           |           |           |         |           |           |           |         |           |           |           |              |                  |           |           |              |                  |              |              |
| 4K2K 25         | 4K2K@25Hz  | 1920X1080    | 1920X1080         |            |                   |          |      |         |         |          |      |         |         |             |           |          |          |             |           |          |          |              |            |          |          |              |            |          |          |              |            |          |          |              |            |           |           |              |            |          |          |         |           |           |           |         |           |           |           |         |           |           |           |              |                  |           |           |              |                  |              |              |
| 4K2K 30         | 4K2K@30Hz  | 1680x1050    | 1680x1050         |            |                   |          |      |         |         |          |      |         |         |             |           |          |          |             |           |          |          |              |            |          |          |              |            |          |          |              |            |          |          |              |            |           |           |              |            |          |          |         |           |           |           |         |           |           |           |         |           |           |           |              |                  |           |           |              |                  |              |              |
| 4K2K(420) 50    | 4K2K@50Hz(4:2:0)   | 1600x1200    | 1600x1200         |            |                   |          |      |         |         |          |      |         |         |             |           |          |          |             |           |          |          |              |            |          |          |              |            |          |          |              |            |          |          |              |            |           |           |              |            |          |          |         |           |           |           |         |           |           |           |         |           |           |           |              |                  |           |           |              |                  |              |              |
| 4K2K(420) 60    | 4K2K@60Hz(4:2:0)   | 1920x1200 RB | 1920x1200 RB      |            |                   |          |      |         |         |          |      |         |         |             |           |          |          |             |           |          |          |              |            |          |          |              |            |          |          |              |            |          |          |              |            |           |           |              |            |          |          |         |           |           |           |         |           |           |           |         |           |           |           |              |                  |           |           |              |                  |              |              |

## Setting the Audio Source

To set the audio source:

1. On the front panel click **MENU**. The menu appears.
2. Click **AUDIO** and set the following:

| Menu Item   | Function  |
|-------------|---|
| DP SOURCE   | Set to ANALOG, EMBEDDED (default) or AUTOMATIC.                                     |
| HDMI SOURCE | Set to ANALOG, EMBEDDED (default) or AUTOMATIC.                                     |
| DELAY       | Set the audio delay time to OFF (default), 40ms, 50ms, up to 200ms (in 10ms steps). |

## Setting OSD Parameters

To set the OSD parameters:

1. On the front panel click **MENU**. The menu appears.
2. Click **OSD** and set the following:

| Menu Item    | Function   |
|--------------|--|
| H POSITION   | Set the horizontal position of the OSD.  |
| V POSITION   | Set the vertical position of the OSD.  |
| TIMER        | Set the timeout period in seconds.   |
| TRANSPARENCY | Set the OSD background between 100 (transparent) and 0 (opaque).   |
| DISPLAY      | Select the information displayed on-screen during operation:<br>INFO (default) – the information appears for 10 seconds.<br>ON – the information appears constantly.<br>OFF – the information does not appear. |

## Defining Advanced Settings

To set the advanced settings:

1. On the front panel click **MENU**. The menu appears.
2. Click **ADVANCED** and set the following:

| Menu Item       | Function  |
|-----------------|---|
| HDCP ON INPUT:  | Set HDCP on DP and HDMI: either ON (default) or OFF.<br>Setting HDCP support to enabled (ON) or disabled (OFF) on the input allows the source to transmit a non-HDCP signal if required (for example, when working with a Mac computer).  |
| HDCP ON OUTPUT: | Select FOLLOW INPUT, to change its HDCP output setting according to the HDCP of the input.<br>This option is recommended when the HDMI/HDCP output is connected to a splitter/switcher.<br>Select FOLLOW OUTPUT for the scaler to match its HDCP output to the HDCP setting of the HDMI/HDCP acceptor to which it is connected.   |
| AUTO SYNC OFF:  | Turns off the output after a period of not detecting a valid video signal on the input(s) until a valid input is again detected or any keypad is pressed.<br>Set to:<br>Slow – to disable outputs after 2 minutes.<br>Fast – to disable outputs after 10 seconds.<br>Disable – to leave outputs active at all times.  |
| AUTO INPUT:     | Set to:<br>OFF (default) – for manual switching.<br>Last Connected – switches to the last connected input.<br>Scan – scans for a valid input.   |
| AUTO IMAGE:     | When ON, auto image is implemented every time the input is switched to VGA or when the input resolution changes.<br>The auto-image feature calculates the positioning based on the picture connected to the VGA input. Only a “full screen” picture can be used for this auto-positioning – a test pattern (or some other picture) which has black along the entire top, bottom or one of the sides would not be suitable). |
| FREEZE:         | Select to freeze and/or mute the display FREEZE ONLY / FREEZE + MUTE (default) / MUTE ONLY.   |

| Menu Item    | Function   |
|--------------|--|
| EDID MANAGE: | Set DP EDID – to DEF. 1080P, DEF. 4K2K(3G), DEF. 4K2K(4:2:0) or OUTPUT.<br>Set HDMI EDID – to DEF. 1080P, DEF. 4K2K(3G), DEF. 4K2K(4:2:0) or OUTPUT.   |
| HDBT DATA:   | <b>VP-428H2</b> can either pass data via HDBT OUT or use the Step-in feature (see <a href="#">Using the Step-in Feature</a> on page 13).<br>Set to:<br>DATA PORT (default) – to enable passing data via HDBT OUT.<br>STEP-IN 0 – to use Step-in with legacy Step-in-compatible switchers.<br>STEP-IN 4 – to use with new Step-in-compatible switchers. |

## Using the Step-in Feature

When the **VP-428H2** HDBT OUT port is connected to a Step-in compatible switcher via the HDBT OUT port (for example, **VP-558**), you can use the Step-in button to activate the input on that switcher.

To use the Step-in feature first perform the initial setup and then perform a Step-in operation.

### To use the Step-in feature:

1. Perform the initial setup:
  - On the front panel press **MENU**. The menu appears.
  - Click **ADVANCED** and then **HDBT DATA**.
  - Select STEP-IN 0 (legacy) or STEP-IN 4 (new).

The Step-in button on the front panel now operates in conjunction with the compatible receiver.

2. Perform a Step-in operation:
  - On the front panel click **INPUT SELECT** to select an input.
3. Press **STEP-IN** to switch the selected input to the connected switcher.

## Performing Factory Reset

### To perform factory reset:

1. On the front panel click **MENU**. The menu appears.
2. Click **FACTORY** and click **YES**.  
Wait for completion of factory reset.

## Viewing Device Information

### To view the information:

1. On the front panel click **MENU**. The menu appears.
2. Click **INFO**. and view the following information: the selected source, the input and output resolutions, Valens firmware version and software version.

# Firmware Upgrade

## To upgrade the firmware:

1. Save the new firmware file to a memory stick.
2. Disconnect power from the **VP-428H2**.
3. Plug the memory stick into the PROG USB port on the **VP-428H2** front panel.
4. Press and hold the MENU button while reconnecting power to the **VP-428H2**.
5. When the ON LED flashes, release the MENU button (meaning the device is in the FW upgrading mode).
6. When the upgrade is complete, the LED stops flashing and illuminates.
7. Disconnect and reconnect the power cable.
8. Check that the **INFO.** screen shows the latest FW version (see [Viewing Device Information](#) on page [13](#)).

# Technical Specifications

|                          |   |   |
|--------------------------|---|---|
| Inputs                   | 1 DP  | On a DisplayPort connector                          |
|                          | 1 HDMI  | On a female HDMI connector                          |
|                          | 1 PC  | On a 15-pin HD connector                            |
|                          | 1 Stereo Analog Unbalanced Audio  | On a 3.5mm mini jack                                |
|                          | 1 IR IN   | On a 3.5mm mini jack                                |
| Outputs                  | HDBT OUT  | On an RJ-45 port                                    |
|                          | 1 IR OUT  | On a 3.5mm mini jack                                |
| Ports                    | 1 USB   | On a female USB-A connector                         |
|                          | 1 DATA RS-232   | On a 3-pin terminal block for serial link extension |
|                          | 1 CTRL RS-232   | On a 3-pin terminal block for device control        |
|                          | 1 Ethernet  | On an RJ-45 female connector for port tunneling     |
| Video                    | Max Bandwidth   | 10.2Gbps (3.4Gbps per graphic channel)              |
|                          | Max Resolution  | 4K UHD @60Hz (4:2:0) 24bpp resolution               |
|                          | Compliance  | HDMI 2.0 and HDCP 2.2                               |
|                          | Switching Time Between Inputs   | 2 to 3 seconds                                      |
|                          | Video Latency   | 2 to 3 frames                                       |
| Input Resolutions        | 640x350@60/70/85Hz, 640x400@70/85Hz, 640x480@57/60/66/72/85Hz, 720x400@70/85Hz, 720x480@60i/60p/60Hz, 720x576@50i/50p/60Hz, 800x600@56/60/72/75/85Hz, 832x624@75Hz, 848x480@59/60Hz, 864x648@60Hz, 1024x768@43i/60/70/75/85Hz, 1152x864@60/70/75/85Hz, 1152x870@60/75Hz, 1280x720@25p/30p/50p/60p/75Hz, 1280x768@50/60 (RB)/60/75/85Hz, 1280x800@59/60/75/85Hz, 1280x960@60/75/85Hz, 1280x1024@59/60/72/75/76/85Hz, 1360x768@60Hz, 1366x768@60Hz, 1400x1050@59/60/75Hz, 1440x900@60 (RB)/60/75/85Hz, 1600x900@60 (RB)/60/75Hz, 1600x1024@60/75Hz, 1600x1200@51/59/60/65/70/75Hz, 1680x1050@59/60/75Hz, 1920x1200@59/60/65/75Hz, 1920x1080@50i/60i/24p/25p/30p/50p/60p/60Hz, 920x1080@60s, 1920x1080@50vesa, 3840x2160@24p/25p/30p/50p/50p (420)/60p/60p (420)/60p (RB), 4096x2160@24p/25p/30p/50p/50p (420)/60p/60p (420) |   |
| Output Resolutions       | Native, 640x480@60Hz, 720x480P@60Hz, 720x576P@50Hz, 800x600@60Hz, 1024x768@60Hz, 1280x720@60Hz, 1280x768@60Hz, 1280x800@60Hz, 1280x1024@60Hz, 1360x768@60Hz, 1400x1050@60Hz, 1440x900@60Hz, 1600x1200@60Hz, 1680x1050@60Hz, 1920x1080@60Hz, 1920x1200@60Hz, 1280x720P@50/60Hz, 1920x1080P@24/25/30/50/60Hz, 4K@24/25/30Hz, 4K2K(4:2:0)@50/60Hz  |   |
| Power                    | Consumption   | 48V DC, 410mA                                       |
|                          | Source  | 48V DC, 1.36A                                       |
| Environmental Conditions | Operating Temperature   | 0° to +40°C (32° to 104°F)                          |
|                          | Storage Temperature   | -40° to +70°C (-40° to 158°F)                       |
|                          | Humidity  | 10% to 90%, RHL non-condensing                      |
| Regulatory Compliance    | Safety  | CE, UL  |
|                          | Environmental   | RoHs, WEEE  |

|   |                               |  |
|---|-------------------------------|--|
| Enclosure   | Size                          | MegaTOOLS  |
|   | Type                          | Aluminum   |
|   | Cooling                       | Convection Ventilation                           |
| General   | Net Dimensions (W, D, H)      | 18.8cm x 22.3cm x 2.5cm<br>(7.4" x 5.7" x 1")    |
|   | Shipping Dimensions (W, D, H) | 21.2cm x 35.1cm x 7.2cm<br>(8.4" x 13.8" x 2.8") |
|   | Net Weight                    | 0.87kg (1.9lbs) approx.                          |
|   | Shipping Weight               | 1.43kg (3.1lbs) approx.                          |
| Accessories   | Included                      | Power adapter and cord                           |
| Specifications are subject to change without notice at <a href="http://www.kramerav.com">www.kramerav.com</a> |                               |  |

## Default Communication Parameters

|   |   |
|---|---|
| <b>RS-232</b>                                       |   |
| Baud Rate:  | 9,600   |
| Data Bits:  | 8   |
| Stop Bits:  | 1   |
| Parity:   | None  |
| <b>RS-232 Command Protocol</b>                      |   |
| Command Format:                                     | ASCII protocol 3000   |
| Example (Route the video HDMI input to the output): | #ROUTE 12,1,1<cr>   |
| <b>Full Factory Reset</b>                           |   |
| OSD   | Go to : Menu-> Setup -> Factory Reset -> press Enter to confirm                   |
| Front panel buttons                                 | Press the Reset to XGA/1080p Button while plugging the power to reset the machine |

## Input Resolutions

| Resolution/Refresh Rate  | DP  | PC  | HDMI |
|--------------------------|-----|-----|------|
| 480I/576I                | Yes | No  | Yes  |
| 480P/576P                | Yes | No  | Yes  |
| 720P@(60/50)             | Yes | No  | Yes  |
| 1080I@(60/50)            | Yes | No  | Yes  |
| 1080P@(60/50)            | Yes | No  | Yes  |
| 1080P@(24/25/30)         | Yes | No  | Yes  |
| 640x480@(60/67/72/75/85) | Yes | Yes | Yes  |
| 800x600@(56/60/72/75)    | Yes | Yes | Yes  |
| 1024x768@(60/70/75)      | Yes | Yes | Yes  |
| 1280x1024@(60/75)        | Yes | Yes | Yes  |
| 1280X960@60              | Yes | Yes | Yes  |
| 1280X720@60              | Yes | Yes | Yes  |
| 1920X1080@60             | Yes | No  | Yes  |
| 1600X1200@60             | Yes | Yes | Yes  |
| 1280x768@60              | Yes | Yes | Yes  |
| 1280x800@60              | Yes | Yes | Yes  |
| 1360x768@60              | Yes | Yes | Yes  |
| 1366x768@60              | Yes | Yes | Yes  |

| Resolution/Refresh Rate | DP  | PC  | HDMI |
|-------------------------|-----|-----|------|
| 1400x1050@60            | Yes | Yes | Yes  |
| 1600X900@60 RB          | Yes | No  | Yes  |
| 1680x1050@60            | Yes | Yes | Yes  |
| 1920x1200@60 RB         | Yes | Yes | Yes  |
| 4K2K@(24/25/30/50/60)   | Yes | No  | Yes  |
| 4K2K(4:2:0)@(50/60)     | Yes | No  | Yes  |

## Output Resolutions

| Resolution/Refresh Rate  | HDBT |
|--------------------------|------|
| 640x480 60Hz             | Yes  |
| 800x600 60Hz             | Yes  |
| 1024x768 60Hz            | Yes  |
| 1280x768 60Hz            | Yes  |
| 1360x768 60Hz            | Yes  |
| 1280x720 60Hz            | Yes  |
| 1280x800 60Hz            | Yes  |
| 1280x1024 60Hz           | Yes  |
| 1440x900 60Hz            | Yes  |
| 1400x1050 60Hz           | Yes  |
| 1680x1050 60Hz           | Yes  |
| 1920x1080 60Hz           | Yes  |
| 1920x1200 RB 60Hz        | Yes  |
| 480P 60Hz                | Yes  |
| 576P 50Hz                | Yes  |
| 720P (50/60Hz)           | Yes  |
| 1080P (24/25/30/50/60Hz) | Yes  |
| 4K2K (24/25/30Hz)        | Yes  |
| 4K2K (4:2:0) (50/60Hz)   | Yes  |

# Protocol 3000

The VP-428H2 4K HDBT Transmitter/Scaler can be operated using the Kramer Protocol 3000 serial commands. The command framing varies according to how you interface with the VP-428H2.

Generally, a basic video input switching command that routes a layer 1 video signal to HDMI out 1 from HDMI input 2 (ROUTE 1, 1, 2), is entered as follows:

- Terminal communication software, such as Hercules:

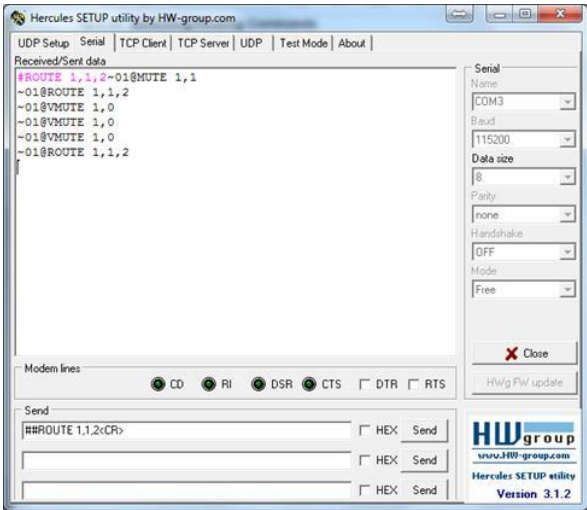

**i** The framing of the command varies according to the terminal communication software.

- K-Touch Builder (Kramer software):

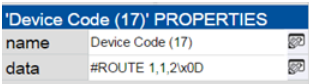

- K-Config (Kramer configuration software):

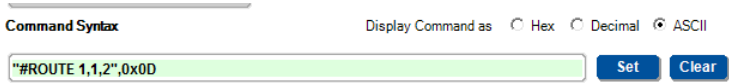

**i** All the examples provided in this section are based on using the K-Config software.

You can enter commands directly using terminal communication software (e.g., Hercules) by connecting a PC to the serial or Ethernet port on your device. To enter `CR` press the Enter key (`LF` is also sent but is ignored by the command parser).

Commands sent from various non-Kramer controllers (e.g., Crestron) may require special coding for some characters (such as, `/X##`). For more information, refer to your controller's documentation.

For more information about Protocol 3000 commands, see:

- [Understanding Protocol 3000](#) on page [19](#).
- [Kramer Protocol 3000 Syntax](#) on page [20](#).
- [Protocol 3000 Commands](#) on page [21](#).

---

## Understanding Protocol 3000

Protocol 3000 commands are structured according to the following:

- **Command** – A sequence of ASCII letters (A-Z, a-z and -). A command and its parameters must be separated by at least one space.
- **Parameters** – A sequence of alphanumeric ASCII characters (0-9, A-Z, a-z and some special characters for specific commands). Parameters are separated by commas.
- **Message string** – Every command entered as part of a message string begins with a message starting character and ends with a message closing character.



A string can contain more than one command. Commands are separated by a pipe ( | ) character.

- **Message starting character:**
  - # – For host command/query
  - ~ – For device response
- **Device address** – K-NET Device ID followed by @ (optional, K-NET only)
- **Query sign** – ? follows some commands to define a query request
- **Message closing character:**
  - CR – Carriage return for host messages (ASCII 13)
  - CR LF – Carriage return for device messages (ASCII 13) and line-feed (ASCII 10)
- **Command chain separator character** – Multiple commands can be chained in the same string. Each command is delimited by a pipe character ( | ). When chaining commands, enter the message starting character and the message closing character only at the beginning and end of the string.



Spaces between parameters or command terms are ignored. Commands in the string do not execute until the closing character is entered. A separate response is sent for every command in the chain.

## Kramer Protocol 3000 Syntax

The Kramer Protocol 3000 syntax uses the following delimiters:

- **CR** = Carriage return (ASCII 13 = 0x0D)
- **LF** = Line feed (ASCII 10 = 0x0A)
- **SP** = Space (ASCII 32 = 0x20)

Some commands have short name syntax in addition to long name syntax to enable faster typing. The response is always in long syntax.

The Protocol 3000 syntax is in the following format:

- **Host Message Format:**

| Start | Address (optional) | Body           | Delimiter |
|-------|--------------------|----------------|-----------|
| #     | <i>Device_id@</i>  | <b>Message</b> | <b>CR</b> |

- **Simple Command** – Command string with only one command without addressing:

| Start | Body   | Delimiter |
|-------|--|-----------|
| #     | <b>Command</b> <b>SP</b><br><i>Parameter_1,Parameter_2,...</i> | <b>CR</b> |

- **Command String** – Formal syntax with command concatenation and addressing:

| Start | Address           | Body   | Delimiter |
|-------|-------------------|--|-----------|
| #     | <i>Device_id@</i> | <b>Command_1</b><br><i>Parameter1_1,Parameter1_2,... </i><br><b>Command_2</b><br><i>Parameter2_1,Parameter2_2,... </i><br><b>Command_3</b><br><i>Parameter3_1,Parameter3_2,... ...</i> | <b>CR</b> |

- **Device Message Format:**

| Start | Address (optional) | Body           | Delimiter           |
|-------|--------------------|----------------|---------------------|
| ~     | <i>Device_id@</i>  | <b>Message</b> | <b>CR</b> <b>LF</b> |

- **Device Long Response** – Echoing command:

| Start | Address (optional) | Body   | Delimiter           |
|-------|--------------------|--|---------------------|
| ~     | <i>Device_id@</i>  | <b>Command</b> <b>SP</b> [ <i>Param1 ,Param2 ...</i> ] <b>result</b> | <b>CR</b> <b>LF</b> |

## Protocol 3000 Commands

This section includes the following commands:

- [Common Commands](#) on page [21](#).
- [Step-in Commands](#) on page [26](#).
- [System Commands](#) on page [27](#).
- [Video Commands](#) on page [28](#).
- [Switching/Routing Commands](#) on page [30](#).
- [Audio Commands](#) on page [31](#).

### Common Commands

| Command    | Description                                    |
|------------|--|
| #          | Protocol handshaking (system mandatory)        |
| BUILD-DATE | Get device build date (system mandatory)       |
| FACTORY    | Reset to factory default configuration         |
| HELP       | Get command list (system mandatory)            |
| MODEL?     | Get device model (system mandatory)            |
| PROT-VER?  | Get device protocol version (system mandatory) |
| RESET      | Reset device (system mandatory)                |
| SN?        | Get device serial number (system mandatory)    |
| VERSION?   | Read device firmware version                   |
| DISPLAY    | Read if output is valid                        |
| NAME       | Set/get machine (DNS) name                     |
| NAME-RST   | Reset machine name to factory default (DNS)    |

#

| Functions   |                      | Permission             | Transparency |
|---|----------------------|------------------------|--------------|
| Set:  | #                    | End User               | Public       |
| Get:  | -                    | -                      | -            |
| Description   |                      | Syntax                 |              |
| Set:  | Protocol handshaking | # <input type="text"/> |              |
| Get:  | -                    | -                      |              |
| Response  |                      |                        |              |
| ~ <input type="text"/> <input type="text"/> <input type="text"/> @SPOK <input type="text"/> <input type="text"/> <input type="text"/>                     |                      |                        |              |
| Notes   |                      |                        |              |
| Validates the Protocol 3000 connection and gets the machine number.<br>Step-in master products use this command to identify the availability of a device. |                      |                        |              |
| K-Config Example  |                      |                        |              |
| `#`, 0x0D   |                      |                        |              |

**BUILD-DATE**

| Functions   |                       | Permission                             | Transparency |
|---|-----------------------|--|--------------|
| Set:  | -                     | -                                      | -            |
| Get:  | <b>BUILD-DATE?</b>    | End User                               | Public       |
| Description   |                       | Syntax                                 |              |
| Set:  | -                     | -                                      |              |
| Get:  | Get device build date | # <b>BUILD-DATE?</b> <code>[CR]</code> |              |
| Response  |                       |  |              |
| ~ <code>[nn]</code> @ <b>BUILD-DATE</b> <code>[SP]</code> date <code>[SP]</code> time <code>[CR LF]</code>                                |                       |  |              |
| Parameters  |                       |  |              |
| date – Format: YYYY/MM/DD where YYYY = Year, MM = Month, DD = Day<br>time – Format: hh:mm:ss where hh = hours, mm = minutes, ss = seconds |                       |  |              |
| K-Config Example  |                       |  |              |
| "#BUILD-DATE?", 0x0D  |                       |  |              |

**FACTORY**

| Functions   |   | Permission                         | Transparency |
|---|---|------------------------------------|--------------|
| Set:  | <b>FACTORY</b>                                | End User                           | Public       |
| Get:  | -   | -                                  | -            |
| Description   |   | Syntax                             |              |
| Set:  | Reset device to factory default configuration | # <b>FACTORY</b> <code>[CR]</code> |              |
| Get:  | -   | -                                  |              |
| Response  |   |                                    |              |
| ~ <code>[nn]</code> @ <b>FACTORY</b> <code>[SP]</code> OK <code>[CR LF]</code>  |   |                                    |              |
| Notes   |   |                                    |              |
| This command deletes all user data from the device. The deletion can take some time. Your device may require powering off and powering on for the changes to take effect. |   |                                    |              |
| K-Config Example  |   |                                    |              |
| "#FACTORY", 0x0D  |   |                                    |              |

**HELP**

| Functions   |   | Permission                      | Transparency |
|---|---|---------------------------------|--------------|
| Set:  | -   | -                               | -            |
| Get:  | <b>HELP</b>                                   | End User                        | Public       |
| Description   |   | Syntax                          |              |
| Set:  | -   | -                               |              |
| Get:  | Get command list or help for specific command | # <b>HELP</b> <code>[CR]</code> |              |
| Response  |   |                                 |              |
| Multi-line: ~ <code>[nn]</code> @Device available protocol 3000 commands: <code>[CR LF]</code> command, <code>[SP]</code> command... <code>[CR LF]</code> |   |                                 |              |
| Parameters  |   |                                 |              |
| <i>COMMAND_NAME</i> – name of a specific command  |   |                                 |              |
| Notes   |   |                                 |              |
| To get help for a specific command use: <b>HELP</b> <code>[SP]</code> <i>COMMAND_NAME</i> <code>[CR LF]</code>  |   |                                 |              |
| K-Config Example  |   |                                 |              |
| "#HELP", 0x0D   |   |                                 |              |

**MODEL**

| Functions  |                  | Permission                                  | Transparency |
|--|------------------|---|--------------|
| Set:   | -                | -   | -            |
| Get:   | <b>MODEL?</b>    | End User                                    | Public       |
| Description  |                  | Syntax                                      |              |
| Set:   | -                | -   |              |
| Get:   | Get device model | # <b>MODEL?</b> <input type="checkbox"/> CR |              |
| Response   |                  |   |              |
| ~ <input type="checkbox"/> <input type="checkbox"/> @ <b>MODEL</b> <input type="checkbox"/> SPmodel_name <input type="checkbox"/> CR LF  |                  |   |              |
| Parameters   |                  |   |              |
| model_name – String of up to 19 printable ASCII chars  |                  |   |              |
| Notes  |                  |   |              |
| This command identifies equipment connected to Step-in master products and notifies of identity changes to the connected equipment. The Matrix saves this data in memory to answer REMOTE-INFO requests. |                  |   |              |
| K-Config Example   |                  |   |              |
| `#MODEL?`, 0x0D  |                  |   |              |

**PROT-VER**

| Functions  |                             | Permission                                     | Transparency |
|--|-----------------------------|--|--------------|
| Set:   | -                           | -  | -            |
| Get:   | <b>PROT-VER?</b>            | End User                                       | Public       |
| Description  |                             | Syntax   |              |
| Set:   | -                           | -  |              |
| Get:   | Get device protocol version | # <b>PROT-VER?</b> <input type="checkbox"/> CR |              |
| Response   |                             |  |              |
| ~ <input type="checkbox"/> <input type="checkbox"/> @ <b>PROT-VER</b> <input type="checkbox"/> SP3000:version <input type="checkbox"/> CR LF |                             |  |              |
| Parameters   |                             |  |              |
| version - XX.XX where X is a decimal digit   |                             |  |              |
| K-Config Example   |                             |  |              |
| `#PROT-VER?`, 0x0D   |                             |  |              |

**RESET**

| Functions  |              | Permission                                 | Transparency |
|--|--------------|--|--------------|
| Set:   | <b>RESET</b> | Administrator                              | Public       |
| Get:   | -            | -  | -            |
| Description  |              | Syntax                                     |              |
| Set:   | Reset device | # <b>RESET</b> <input type="checkbox"/> CR |              |
| Get:   | -            | -  |              |
| Response   |              |  |              |
| ~ <input type="checkbox"/> <input type="checkbox"/> @ <b>RESET</b> <input type="checkbox"/> SPOK <input type="checkbox"/> CR LF  |              |  |              |
| Notes  |              |  |              |
| To avoid locking the port due to a USB bug in Windows, disconnect USB connections immediately after running this command. If the port was locked, disconnect and reconnect the cable to reopen the port. |              |  |              |
| K-Config Example   |              |  |              |
| `#RESET`, 0x0D   |              |  |              |

**SN?**

| Functions   |                          | Permission                     | Transparency |
|---|--------------------------|--------------------------------|--------------|
| Set:  | -                        | -                              | -            |
| Get:  | <b>SN?</b>               | End User                       | Public       |
| Description   |                          | Syntax                         |              |
| Set:  | -                        | -                              |              |
| Get:  | Get device serial number | # <b>SN?</b> <code>[CR]</code> |              |
| Response  |                          |                                |              |
| ~ <code>[nn]</code> @ <b>SN?</b> <code>[SP]</code> serial_number <code>[CR LF]</code> |                          |                                |              |
| Parameters  |                          |                                |              |
| serial_number – 11 decimal digits, factory assigned                                   |                          |                                |              |
| Notes   |                          |                                |              |
| This device has a 14 digit serial number, only the last 11 digits are displayed.      |                          |                                |              |
| K-Config Example  |                          |                                |              |
| `#SN?`, 0x0D  |                          |                                |              |

**VERSION?**

| Functions   |                             | Permission                          | Transparency |
|---|-----------------------------|-------------------------------------|--------------|
| Set:  | -                           | -                                   | -            |
| Get:  | <b>VERSION?</b>             | End User                            | Public       |
| Description   |                             | Syntax                              |              |
| Set:  | -                           | -                                   |              |
| Get:  | Get firmware version number | # <b>VERSION?</b> <code>[CR]</code> |              |
| Response  |                             |                                     |              |
| ~ <code>[nn]</code> @ <b>VERSION?</b> <code>[SP]</code> firmware_version <code>[CR LF]</code> |                             |                                     |              |
| Parameters  |                             |                                     |              |
| firmware_version – XX.XX.XXXX where the digit groups are: major.minor.build version           |                             |                                     |              |
| K-Config Example  |                             |                                     |              |
| `#VERSION?`, 0x0D   |                             |                                     |              |

**DISPLAY**

| Functions   |                       | Permission   | Transparency |
|---|-----------------------|--|--------------|
| Set:  | -                     | -  | -            |
| Get:  | <b>DISPLAY?</b>       | End User   | System       |
| Description   |                       | Syntax   |              |
| Set:  | -                     | -  |              |
| Get:  | Get output HPD status | # <b>DISPLAY?</b> <code>[SP]</code> P1 <code>[CR]</code> |              |
| Response  |                       |  |              |
| ~ <code>[nn]</code> @ <b>DISPLAY?</b> <code>[SP]</code> P1 <code>[CR LF]</code>   |                       |  |              |
| Parameters  |                       |  |              |
| P1 – Output number: 1 (HDBaseT)   |                       |  |              |
| Response Triggers   |                       |  |              |
| After execution, response is sent to the com port from which the Get was received.<br>Response is sent after every change in output HPD status ON to OFF.<br>Response is sent after every change in output HPD status OFF to ON and ALL parameters (new EDID, etc.) are stable and valid (new EDID, etc.) are stable and valid. |                       |  |              |
| K-Config Example  |                       |  |              |
| Get the output HPD status of HDMI 1:<br>`#DISPLAY?`, 0x0D   |                       |  |              |

**NAME**

| Functions  |   | Permission                                  | Transparency |
|--|---|---|--------------|
| Set:   | <b>NAME</b>                                       | Administrator                               | Public       |
| Get:   | <b>NAME?</b>                                      | End User                                    | Public       |
| Description  |   | Syntax                                      |              |
| Set:   | Set machine (DNS) name                            | # <b>NAME</b> [SP] <i>machine_name</i> [CR] |              |
| Get:   | Get machine (DNS) name                            | # <b>NAME?</b> [CR]                         |              |
| Response   |   |   |              |
| Set:   | ~nn@ <b>NAME</b> [SP] <i>machine_name</i> [CR LF] |   |              |
| Get:   | ~nn@ <b>NAME</b> [SP] <i>machine_name</i> [CR LF] |   |              |
| Parameters   |   |   |              |
| machine_name – String of up to 14 alpha-numeric characters (can include hyphens but not at the beginning or end)                                       |   |   |              |
| Notes  |   |   |              |
| The machine name is not the same as the model name. The machine name is used to identify a specific machine or a network in use (with DNS feature on). |   |   |              |
| K-Config Example   |   |   |              |
| Set the DNS name of the device to “room-442”:<br>`#NAME room-442”,0x0D   |   |   |              |

**NAME-RST**

| Functions  |   | Permission             | Transparency |
|--|---|------------------------|--------------|
| Set:   | <b>NAME-RST</b>                             | Administrator          | Public       |
| Get:   | -   | -                      | -            |
| Description  |   | Syntax                 |              |
| Set:   | Reset machine (DNS) name to factory default | # <b>NAME-RST</b> [CR] |              |
| Get:   | -   | -                      |              |
| Response   |   |                        |              |
| ~nn@ <b>NAME-RST</b> [SP]OK[CR LF]   |   |                        |              |
| Notes  |   |                        |              |
| Factory default of machine (DNS) name is “KRAMER_” + 4 last digits of device serial number |   |                        |              |
| K-Config Example   |   |                        |              |
| Reset the machine name (S/N last digits are 0102):<br>`#NAME-RST KRAMER_0102”,0x0D         |   |                        |              |

## Step-in Commands

| Command   | Description                     |
|-----------|---------------------------------|
| BTN       | Set/get module state            |
| STEPIN-CP | Get module STEP-IN capabilities |

### BTN

| Command Name  |                  | Permission                           | Transparency |
|---|------------------|--------------------------------------|--------------|
| Set:  | <b>BTN</b>       | User                                 | Public       |
| Get:  | <b>BTN?</b>      | User                                 | Public       |
| Description   |                  | Syntax                               |              |
| Set:  | Set module state | # <b>BTN</b> [SP]button_num,mode[CR] |              |
| Get:  | Get module state | # <b>BTN?</b> [SP]button_num[CR]     |              |
| Response  |                  |                                      |              |
| ~nn@ <b>BTN</b> [SP]button_num,mode[CR LF]  |                  |                                      |              |
| Parameters  |                  |                                      |              |
| button_num – 1 (button number)<br>mode – 0 (mute), 1 (active) 0xff (pending)  |                  |                                      |              |
| Notes   |                  |                                      |              |
| <p>After a SET command, LEDs show the button status:<br/>           mute – button LED off<br/>           active – button LED on<br/>           pending – button LED flashing</p> <p>The Step-in master uses this command to get the actual status and identify if the device is in pending Step-in request.<br/>           In reply to the Step-in request, the Step-in master updates the button status by sending set to activate and configures the Step-in action. Other Step-in clients are set to mute.</p> |                  |                                      |              |
| K-Config Example  |                  |                                      |              |
| Set the step-in button to active:<br>`#BTN 1,1`,0x0D  |                  |                                      |              |

### STEPIN-CP?

| Command Name   |                                 | Permission               | Transparency |
|--|---------------------------------|--------------------------|--------------|
| Set:   | -                               | -                        | -            |
| Get:   | <b>STEPIN-CP?</b>               | End User                 | Public       |
| Description  |                                 | Syntax                   |              |
| Set:   | -                               | -                        |              |
| Get:   | Get module Step-in capabilities | # <b>STEPIN-CP?</b> [CR] |              |
| Response   |                                 |                          |              |
| ~nn@ <b>STEPIN-CP</b> [SP]capabilities,num_of_inputs,num_of_cntl_btn[CR LF]  |                                 |                          |              |
| Parameters   |                                 |                          |              |
| capabilities – 1 (module supports Step-in), 0 (module doesn't support Step-in)<br>num_of_inputs – 3<br>num_of_cntl_btn – 3<br>type – video port type: 2 (HDMI), 3 (DisplayPort), 6 (VGA) |                                 |                          |              |
| Notes  |                                 |                          |              |
| If a module does not support step-in it might respond with an error "command not supported".   |                                 |                          |              |
| K-Config Example   |                                 |                          |              |
| Get step-in capabilities:<br>`#STEPIN-CP?`,0x0D  |                                 |                          |              |

## System Commands

| Command  | Description       |
|----------|-------------------|
| HDCP-MOD | Set/get HDCP mode |

### HDCP-MOD

| Functions  |               | Permission                             | Transparency |
|--|---------------|--|--------------|
| Set:   | HDCP-MOD      | Administrator                          | Public       |
| Get  | HDCP-MOD?     | End User                               | Public       |
| Description  |               | Syntax                                 |              |
| Set:   | Set HDCP mode | #HDCP-MOD[SP]stage, stage_id, mode[CR] |              |
| Get:   | Get HDCP mode | #HDCP-MOD?[SP]stage, stage_id[CR]      |              |
| Response   |               |  |              |
| Set/get: ~[nn]@HDCP-MOD[SP]stage, stage_id[CR] LF  |               |  |              |
| Parameters   |               |  |              |
| stage – 0 (In), 1 (Out)  |               |  |              |
| stage_id – For input: 0 (DP), 1 (HDMI), 2 (PC); for output: 1 (HDBaseT)  |               |  |              |
| mode – Status for input: 0 (Off), 1 (On) status for output: 2 (Follow In), 3 (Follow Out)  |               |  |              |
| Response Triggers  |               |  |              |
| Response is sent to the com port from which the Set (before execution) / Get command was received  |               |  |              |
| Response is sent to all com ports after execution if HDCP-MOD was set by any other external control device (button press, device menu and similar) or HDCP mode changed. |               |  |              |
| Notes  |               |  |              |
| Set HDCP working mode on the device input:   |               |  |              |
| <ul style="list-style-type: none"> <li>HDCP supported – HDCP_ON (default)</li> <li>HDCP not supported – HDCP OFF</li> </ul>  |               |  |              |
| HDCP supports changes following a detected sink - MIRROR OUTPUT  |               |  |              |
| K-Config Example   |               |  |              |
| Set the DP input HDCP off:<br>`#HDCP-MOD 0,0,0",0x0D`  |               |  |              |

## Video Commands

| Command     | Description                      |
|-------------|----------------------------------|
| VID-RES     | Set/get ADC (VGA) sampling phase |
| VFRZ        | Set/get the freeze on output     |
| IMAGE-PROP  | Set/get the image size           |
| SCLR-PCAUTO | Set PC auto sync of scaler       |

### VID-RES

| Command Name  |                      | Permission   | Transparency |
|---|----------------------|--|--------------|
| Set:  | <b>VID-RES</b>       | End User   | Public       |
| Get:  | <b>VID-RES?</b>      | End User   | Video        |
| Description   |                      | Syntax   |              |
| Set:  | Set video resolution | #VID-RES[SP]stage, stage_id, is_native, resolution[CR] |              |
| Get:  | Get video resolution | #VID-RES?[SP]stage, stage_id, is_native[CR]            |              |
| Response  |                      |  |              |
| ~nn@VID-RES[SP]stage, stage_id, is_native, resolution[CR LF]  |                      |  |              |
| Parameters  |                      |  |              |
| stage – 0 (Input), 1 (Output)   |                      |  |              |
| stage_id – 1 (Scaler)   |                      |  |              |
| is_native – 0 (Off), 1 (On)   |                      |  |              |
| resolution – Select video resolutions: 0-28 (see <a href="#">Output Resolutions Key</a> on page 32)   |                      |  |              |
| Response triggers   |                      |  |              |
| <ul style="list-style-type: none"> <li>After execution, response is sent to the com port from which the <b>Set /Get</b> was received</li> <li>After execution, response is sent to all com ports if <b>VID-RES</b> was set by any other external control device (button press, device menu and similar)</li> </ul>  |                      |  |              |
| Notes   |                      |  |              |
| <ol style="list-style-type: none"> <li>The “Set” command is only applicable when stage = 1 (Output)</li> <li>The “Set” command with is_native = 1 (On), sets the native resolution on the selected output (resolution index sent = 0). The device sends as an answer the actual VIC ID of native resolution.</li> <li>The “Get” command with is_native = 1 (On) returns the native resolution VIC; when is_native = 1 (Off), it returns the current resolution</li> </ol> |                      |  |              |
| K-Config Example  |                      |  |              |
| Set video resolution on output to 1400x1050@60Hz:<br>`#VID-RES 1,1,0,50",0x0D`  |                      |  |              |

### VFRZ

| Command Name                                      |                             | Permission                       | Transparency |
|---|-----------------------------|----------------------------------|--------------|
| Set:  | <b>VFRZ</b>                 | End User                         | -            |
| Get:  | <b>VFRZ?</b>                | End User                         | Video        |
| Description                                       |                             | Syntax                           |              |
| Set:  | Set freeze video on output  | #VFRZ[SP]out_id, freeze_flag[CR] |              |
| Get:  | Get freeze on output status | #VFRZ?[SP]out_id[CR]             |              |
| Response  |                             |                                  |              |
| Set / Get: ~nn@VFRZ[SP]out_id, freeze_flag[CR LF] |                             |                                  |              |
| Parameters  |                             |                                  |              |
| Out_id – 1 (Scaler)                               |                             |                                  |              |
| Freeze_flag – freeze status: 0 (Off), 1 (On)      |                             |                                  |              |
| K-Config Example                                  |                             |                                  |              |
| Set video freeze off:<br>`#VFRZ 1,0",0x0D`        |                             |                                  |              |

**IMAGE PROP**

| Command Name  |                      | Permission   | Transparency |
|---|----------------------|--|--------------|
| Set:  | <b>IMAGE-PROP</b>    | End User   | Public       |
| Get:  | <b>IMAGE-PROP?</b>   | End User   | Video        |
| Description   |                      | Syntax   |              |
| Set:  | Set video resolution | # <b>IMAGE-PROP</b> <input type="checkbox"/> P1, P2 <input type="checkbox"/> |              |
| Get:  | Get video resolution | # <b>IMAGE-PROP?</b> <input type="checkbox"/> P1 <input type="checkbox"/>    |              |
| Response  |                      |  |              |
| Set / Get: ~ <input type="checkbox"/> @ <b>IMAGE-PROP</b> <input type="checkbox"/> P1, P2... <input type="checkbox"/> <input type="checkbox"/>  |                      |  |              |
| Parameters  |                      |  |              |
| P1 – 1 (Scaler)<br>P2 – Image size: 0 (Over Scan), 1 (Full), 2 (Best Fit), 3 (Pan Scan), 4 (Letter Box), 5 (Under Scan), 6 (Follow In)  |                      |  |              |
| Response triggers   |                      |  |              |
| Response is sent to the com port from which the <b>Set</b> (before execution) / <b>Get</b> command was received. After execution, response is sent to all com ports if <b>CMD-NAME</b> was set any other external control device (button press, device menu and similar) or genlock status was changed. |                      |  |              |
| Notes   |                      |  |              |
| Sets the image properties of the selected scaler  |                      |  |              |
| K-Config Example  |                      |  |              |
| Set the image size to Pan Scan:<br>`# <b>IMAGE-PROP</b> 1, 3", 0x0D   |                      |  |              |

**SCLR-PCAUTO**

| Command Name  |                            | Permission  | Transparency |
|---|----------------------------|---|--------------|
| Set:  | <b>SCLR-PCAUTO</b>         | End User  | Public       |
| Get:  |                            | End User  | Video        |
| Description   |                            | Syntax  |              |
| Set:  | Set PC auto sync of scaler | # <b>SCLR-PCAUTO</b> <input type="checkbox"/> P1, P2 <input type="checkbox"/> |              |
| Get:  |                            |   |              |
| Response  |                            |   |              |
| ~ <input type="checkbox"/> @ <b>SCLR-PCAUTO</b> <input type="checkbox"/> P1, P2... <input type="checkbox"/> <input type="checkbox"/>  |                            |   |              |
| Parameters  |                            |   |              |
| P1 – 1 (Scaler)<br>P2 – 1 (Yes)   |                            |   |              |
| Response triggers   |                            |   |              |
| Response is sent to the com port from which the <b>Set</b> (before execution) / <b>Get</b> command was received. After execution, response is sent to all com ports if <b>CMD-NAME</b> was set any other external control device (button press, device menu and similar) or genlock status was changed. |                            |   |              |
| Notes   |                            |   |              |
| Trigger the Auto Adjust feature of PC input   |                            |   |              |
| K-Config Example  |                            |   |              |
| Set the PC auto sync of the scaler to yes:<br>`# <b>SCLR-PCAUTO</b> 1, 1", 0x0D   |                            |   |              |

## Switching/Routing Commands

| Command  | Description           |
|----------|-----------------------|
| ROUTE    | Set/get layer routing |
| MENU-CMD | Set menu navigation   |

### ROUTE

| Command Name  |                   | Permission                        | Transparency |
|---|-------------------|-----------------------------------|--------------|
| Set:  | <b>ROUTE</b>      | End User                          | -            |
| Get:  | <b>ROUTE?</b>     | End User                          | Switching    |
| Description   |                   | Syntax                            |              |
| Set:  | Set layer routing | # <b>ROUTE</b> [SP]P1, P2, P3[CR] |              |
| Get:  | Get layer routing | # <b>ROUTE?</b> [SP]P1, P2[CR]    |              |
| Response  |                   |                                   |              |
| -nn@ <b>ROUTE</b> [SP]P1, P2, P3[CR] LF   |                   |                                   |              |
| Parameters  |                   |                                   |              |
| P1 – Layer number: 12 (Video+Audio)<br>P2 – 1 (Scaler)<br>P3 – Video inputs: 0 (DP), 1 (HDMI), 2 (PC) |                   |                                   |              |
| Notes   |                   |                                   |              |
| This command replaces all other routing commands.   |                   |                                   |              |
| K-Config Example  |                   |                                   |              |
| Select the PC input to route to the output:<br>`#ROUTE 12, 1, 2", 0x0D                                |                   |                                   |              |

### MENU-CMD

| Command Name                                    |                     | Permission                      | Transparency |
|---|---------------------|---------------------------------|--------------|
| Set:  | <b>MENU-CMD</b>     | End User                        | Public       |
| Get:  |                     | End User                        |              |
| Description                                     |                     | Syntax                          |              |
| Set:  | Set menu navigation | # <b>MENU-CMD</b> [SP]param[CR] |              |
| Get:  |                     |                                 |              |
| Response  |                     |                                 |              |
| -nn@ <b>MENU_CMD</b> [SP]param[CR] LF           |                     |                                 |              |
| Parameters                                      |                     |                                 |              |
| Param -1 (Menu), 2 (Enter), 6 (Right), 7 (Left) |                     |                                 |              |
| Notes   |                     |                                 |              |
| This command emulates menu navigation.          |                     |                                 |              |
| K-Config Example                                |                     |                                 |              |
| Select menu:<br>`#MENU-CMD 1", 0x0D             |                     |                                 |              |

## Audio Commands

| Command          | Description                             |
|------------------|---|
| AUD-EMB          | Set/get audio in video embedding status |
| SCLR-AS          | Set/get the auto sync off timer         |
| SCLR-AUDIO-DELAY | Set/get the scaler audio delay          |

### AUD-EMB

| Command Name   |                                     | Permission   | Transparency |
|--|-------------------------------------|--|--------------|
| Set:   | <b>AUD-EMB</b>                      | End User   | Public       |
| Get:   | <b>AUD-EMB?</b>                     | End User   | Public       |
| Description  |                                     | Syntax   |              |
| Set:   | Set audio in video embedding status | #AUD-EMB <sup>SP</sup> in, out, status <sup>CR</sup> |              |
| Get:   | Get audio in video embedding status | #AUD-EMB? <sup>SP</sup> in, out <sup>CR</sup>        |              |
| Response   |                                     |  |              |
| Set / Get: ~ <sup>nn</sup> @AUD-EMB <sup>SP</sup> in, out, status <sup>CR</sup> LF   |                                     |  |              |
| Parameters   |                                     |  |              |
| in – audio input to be embedded: 0 (DP), 1 (HDMI), 2 (PC)  |                                     |  |              |
| out – 0 (Output)   |                                     |  |              |
| status – embedding status: 0 (Analog), 1 (Embedded), 2 (Automatic)   |                                     |  |              |
| Response triggers  |                                     |  |              |
| Response is sent to the com port from which the Set (before execution)/Get command was received.   |                                     |  |              |
| <ul style="list-style-type: none"> <li>After execution, response is sent to all com ports if AUD-EMB was set by any other external control device (button press, device menu and similar)</li> </ul> |                                     |  |              |
| K-Config Example   |                                     |  |              |
| Embed HDMI input audio:<br>`#AUD-EMB 1, 0, 1", 0x0D`   |                                     |  |              |

### Scaler-As

| Command Name  |  | Permission                                  | Transparency |
|---|--|---|--------------|
| Set:  | <b>SCLR-AS</b>                         | End User                                    | Public       |
| Get:  | <b>SCLR-AS?</b>                        | End User                                    | Audio        |
| Description   |  | Syntax                                      |              |
| Set:  | Set the auto sync off timer            | #SCLR-AS <sup>SP</sup> P1, P2 <sup>CR</sup> |              |
| Get:  | Get the auto sync off timer definition | #SCLR-AS? <sup>SP</sup> P1 <sup>CR</sup>    |              |
| Response  |  |   |              |
| Set / Get: ~ <sup>nn</sup> @SCLR-AS <sup>SP</sup> P1, P2 <sup>CR</sup> LF   |  |   |              |
| Parameters  |  |   |              |
| P1 – Scaler=1   |  |   |              |
| P2 – for setting the auto sync timer: Disable=0, Fast=1, Slow=2   |  |   |              |
| Response triggers   |  |   |              |
| The auto-sync feature determines whether the outputs are turned off when no video is detected on the selected input |  |   |              |
| Notes   |  |   |              |
| Sets the Auto Sync features for the selected Scaler.  |  |   |              |
| K-Config Example  |  |   |              |
| Set the auto sync off timer to slow:<br>`#SCLR-AS 1, 2", 0x0D`  |  |   |              |

## Scaler Audio Delay

| Command Name   |                            | Permission                               | Transparency |
|--|----------------------------|--|--------------|
| Set:   | <b>SCLR-AUDIO-DELAY</b>    | End User                                 | Public       |
| Get:   | <b>SCLR-AUDIO-DELAY?</b>   | End User                                 | Audio        |
| Description  |                            | Syntax                                   |              |
| Set:   | Set the scaler audio delay | # <b>SCLR-AUDIO-DELAY</b> [SP]P1, P2[CR] |              |
| Get:   | Get the scaler audio delay | # <b>SCLR-AUDIO-DELAY?</b> [SP]P1[CR]    |              |
| Response   |                            |  |              |
| Set / Get: ~[nn]@ <b>SCLR-AUDIO-DELAY</b> [SP]P1, P2[CR LF]  |                            |  |              |
| Parameters   |                            |  |              |
| P1 – 1 (Scaler)  |                            |  |              |
| P2 – for setting the audio delay: 0 (Off), 1 (40ms), 2 (50ms), ..., 17 (200ms) in 10ms steps   |                            |  |              |
| Response triggers  |                            |  |              |
| Response is sent to the com port from which the Set (before execution) / Get command was received. After execution, response is sent to all com ports if CMD-NAME was set any other external control device (button press, device menu and similar) or genlock status was changed. |                            |  |              |
| Notes  |                            |  |              |
| Sets the audio delay for the selected audio output   |                            |  |              |
| K-Config Example   |                            |  |              |
| Set the scaler audio delay to 40ms:<br>`#SCLR-AUDIO-DELAY 1,1",0x0D  |                            |  |              |

## Output Resolutions Key

| # | Resolution   | #  | Resolution    | #  | Resolution     |
|---|--------------|----|---------------|----|----------------|
| 0 | Native       | 10 | 1400x1050 60  | 20 | 1920x1080P 25  |
| 1 | 640x480 60   | 11 | 1680x1050 60  | 21 | 1920x1080P 30  |
| 2 | 800x600 60   | 12 | 1600x1200 60  | 22 | 1920x1080P 50  |
| 3 | 1024x768 60  | 13 | 1920x1080 60  | 23 | 1920x1080P 60  |
| 4 | 1280x768 60  | 14 | 1920x1200 60  | 24 | 4K2K 24        |
| 5 | 1360x768 60  | 15 | 720x480P 60   | 25 | 4K2K 25        |
| 6 | 1280x720 60  | 16 | 720x576P 50   | 26 | 4K2K 30        |
| 7 | 1280x800 60  | 17 | 1280x720P 60  | 27 | 4K2K(4:2:0) 50 |
| 8 | 1280x1024 60 | 18 | 1280x720P 50  | 28 | 4K2K(4:2:0) 60 |
| 9 | 1440x900 60  | 19 | 1920x1080P 24 |    |                |



P/N:



2900-300855

Rev:



3



## SAFETY WARNING

Disconnect the unit from the power supply before opening and servicing

For the latest information on our products and a list of Kramer distributors, visit our Web site where updates to this user manual may be found.

We welcome your questions, comments, and feedback.